

LXC7X20/LXC7X10

Generator controller user manual.

Ver1.3 Date: 2013/12/26

LXC 7X20 series



LXC 7X10 series



Version History

Date	Ver	Content
2010-10-20	1.0	Start publishing
2012-08-21	1.1	Increased DTU binding and remote monitoring function
2013-07-01	1.2	Increase the panel can set parameters of the items
2013-12-25	1.3	Default configuration specifications, typical application diagram updated.

Contents

1. Technical parameter.....	4
2. Product overview.....	5
3. Performance and characteristics.....	5
4. Order information and modules comparison.....	7
4.1. Order information.....	7
4.2. Modules comparison.....	8
4.3. Models abbreviation.....	8
5. Operation.....	9
5.1. Indicator light.....	9
5.2. Key functions.....	10
5.3. LCD DISPLAY.....	11
5.4. Basic Parameters setting menu.....	13
5.5. Advanced Parameters setting menu.....	14
6. Start、stop operation.....	14
6.1. Starting sequence:.....	14
6.2. Stopping sequence:.....	15
6.3. Manual start/stop operation.....	15
6.4. Manual start.....	15
6.5. Manual stop.....	16
6.6. LXC7X20 Switch control procedures.....	16
6.6.1. Manual transfer procedures:.....	16
6.6.2. Auto transfer procedures:.....	16
6.7. LXC7X10 Switch control procedures.....	17
6.7.1. Manual transfer procedures:.....	17
6.7.2. Auto control procedures:.....	17
7. SMS Remote control、wireless remote control function description.....	18
7.1. LXI680 connection diagram.....	19
7.2. GSM alarm setting.....	19
7.3. Based on the GPRS DTU remote online monitoring.....	20
7.4. Wireless connection schematic diagram.....	20

7.5. Connect the controller through the DTU remote.....	21
7.6. DTU with the binding of the controller.....	21
7.7. Multilevel password management.....	21
7.8. History query.....	22
7.8.1. Event log.....	22
7.8.2. Historical alarm data query.....	22
8. Protection.....	23
8.1. Shutdown alarm.....	23
8.2. Trip and stop alarm.....	24
8.3. Trip alarm.....	25
8.4. Warnings.....	25
9. Wirings connection.....	27
10. Parameters setting.....	29
10.1. Basic configuration parameters.....	29
10.2. Advanced configuration parameters.....	30
10.3. Defined contents of configurable input ports.....	42
10.4. Enable definition of programmable output ports.....	44
10.5. Defined period output.....	46
10.6. Custom combined output.....	48
10.7. Sensor selection list.....	49
10.8. Pressure unit conversion table.....	49
10.9. Conditions of crank disconnect selection.....	50
11. Typical application.....	51
12. Installation.....	54
13. Common faults and exclusion.....	55
14. Product packaging.....	55

1. Technical parameter

Items	Contents
Operating Voltage	DC8.0V to DC35.0V, Continuous Power Supply.
Power Consumption	<3W(standby:≤2W)
Alternator Input Range 3-Phase4-Wire 3-Phase3-Wire Single-phase2-wire 2-Phase3-Wire:	15V - 360 V AC (ph-N) 26V - 620 V AC (ph-ph) 15V - 360 V AC (ph-N) 15V - 360 V AC (ph-N)
Alternator Frequency	50/60Hz
Speed Sensor voltage VPP	2.2 - 100Vpp (Peak to peak)
Speed Sensor Frequency	10000Hz (max)
Start Relay Output	16Amp Controller Power Voltage Output
Fuel Relay Output	16Amp Controller Power Voltage Output
Programmable Relay Output 1	7Amp 250VAC Voltage Free Output
Programmable Relay Output 2	7Amp 250VAC Voltage Free Output
Programmable Relay Output 3	16Amp 250VAC Voltage Free Output
Programmable Relay Output 4	16Amp 250VAC Voltage Free Output
Programmable Relay Output 5	7Amp Controller Power Voltage Output (LXC7X20)
Programmable Relay Output 6	7Amp Controller Power Voltage Output (LXC7X20)
Case Dimension	210mm x 152 mm x 48 mm
Panel Cutout	186mm x 141mm
C.T. Secondary	5A Rated
Working Conditions	Temperature: (-25~+70)°C Humidity:(20~90)%
Storage Condition	Temperature::(-40~+85)°C
Protection Level	IP55:When waterproof rubber seal installed between the controller and panel fascia. IP42:When waterproof rubber seal is not installed between the controller and panel fascia.
Insulating Intensity	Object: input/output/power Quote standard: IEC688-1992 Test way: AC1.5kV/1min leakage current:3mA
Weight	0.68kg

2. Product overview

LXC7XXXseries of power plant automation controller for the automation and monitoring system of a single diesel generator sets, use 32-bit microprocessor technology, achieve generator sets automatic boot/shutdown, the precision measurement of various parameters, alarm protection and three remote function. The controller uses a large-screen LCD (240*128LCD)graphics display, all the important parameters can be displayed in page, save the page. At the same time can be displayed Chinese、English and other languages, all parameters can be adjusted from the controller panel, can also be a PC through a USB interface tweaks and RS485 or GPRS remote adjustment and monitoring. Its structure is compact, simple wiring, high reliability, automation control systems are widely used in all types of generator sets and fire pumps.

3. Performance and characteristics

LXC7X10:Auto Stare Module, controls genset to start or stop automatically by remote start signal.

LXC7X20:Auto Main Failure, updates based on LXC7X10,especially for automatic system composed by generator and mains.

Main characteristics:

- ❖ With ARM-based 32-bit CPU, highly integrated hardware, new reliability level;
- ❖ 240x128 LCD with backlight, multilingual interface(including English, Chinese or other languages) which can be chosen at the site, making commissioning convenient for factory personnel;
- ❖ All parameters can use the computer via USB, RS232, RS485 interface to connect and adjust, while the internal FLASH memory within the controller in the system when power is not lost;
- ❖ 99% of the parameters can be set directly from the front panel for easy on-site commissioning;
- ❖ RS485 communication port enabling remote control, remote measuring, remote communication via ModBus protocol (controller with RS485 port only);
- ❖ Equipped with SMS(Short Message Service)function. When genset is alarming, controller can send short messages via SMS automatically to max.5 telephone numbers. besides, generator status can be controlled and checked using SMS. With advanced networking capabilities, via GPRS mobile network and Internet connectivity, in any place where the network can be remotely monitor;(Need to install the GPRS module: LXI680);
- ❖ Equipped with CANBUS port and can communicate with J1939 genset. Not only can you monitoring frequently-used data(such as water temperature, oil pressure, speed, fuel consumption and so on)of ECU machine, but also control starting up, shutdown, raising speed and speed droop via CANBUS port (controller with CAN Bus port only);
- ❖ Suitable for 3-phase 4-wire,3-phase 3wire,single phase 2-wire,and 2-phase 3-wire (120/240V)power and 50/60Hz Systems;
- ❖ Collects and shows 3-phase voltage, current, power parameter and frequency of generator or mains;
- ❖ For Mains, controller has over and under voltage, over and under frequency, loss of phase and phase sequence wrong detection functions; For generator, controller has over and under voltage, over and under frequency, loss of phase, phase sequence wrong, over and reverse power, over current functions;
- ❖ 3 fixed analog sensors(temperature, oil pressure and liquid level),more kinds of curves of temperature,oil pressure, fuel level can be used directly and users can define the sensor curves by themselves;
- ❖ 2 configurable sensors can be set as sensor of temperature or fuel level; (Only LXC72X0 have this feature);

- ❖ Protection: Automatic start/stop of the genset, ATS(Auto Transfer Switch)control with perfect fault indication and protection function. When multiple warnings occur, the warning bar will rotate to display them, so that we can analyze the reasons;
- ❖ All output ports are relay-out, And the main output 16A relay outputs and three passive relay output, more user-friendly;
- ❖ Parameter setting: parameters can be modified and stored in internal FLASH memory and cannot be lost even in case of power outage; most of them can be adjusted using front panel of the controller and all of them can be modified using PC via USB or RS485 ports.
- ❖ With advanced networking capabilities, via GPRS mobile network and Internet connectivity, in any place where the network can be remotely monitor;
- ❖ A variety of starting conditions for success (speed sensor, oil pressure, power generation) to select, to facilitate the needs of special occasions;
- ❖ Wide power supply range (8 ~ 35) VDC, can adapt to different environment starting battery voltage, can under the low voltage of starting motor moment continue to work for 3 seconds;
- ❖ Fault history with 200, and can record the fault instant oil pressure ,water temperature, voltage, current and other important parameters;
- ❖ Equipped with real-time clock, scheduled start & stop generator(can be seas start gen-set once a day/week/month with load or not),reach automatic maintenance;
- ❖ Can be used on pumping units and as an indicating instrument (indicate and alarm are enable only, relay is inhibited);
- ❖ 3 set of maintenance functions, can be set for the machine maintenance cycle .Maintenance time to action can be set up(only warning or alarm stop);
- ❖ Waterproof security level IP55 due to rubber seal installed between the controller enclosure and panel fascia;
- ❖ Improved LCD wear-resistance and scratch resistance due to hard screen acrylic;
- ❖ Silicon panel and push buttons for better operation in high-temperature environment,and has a good waterproof performance;
- ❖ Modular design, anti-flaming ABS plastic enclosure, plug gable connection terminals and embedded installation way, compact structure with easy mounting.

Special industry application characteristics:

- ❖ Leasing industry applications: management provides the perfect solution: leased out via PC remote Management of the unit, you can monitor all operating parameters (oil pressure, water temperature, voltage, current, power, etc),you can always change the configuration to protect the unit is not proper application, can record 200 detailed fault information, including: time to failure, because ,when the voltage, current, power, oil pressure, water temperature and other key parameters, and ready to upload to the monitoring machine. Another multi-level password management options to facilitate the lease management;
- ❖ Fire pump industry applications: Close electrical parameter measurement function, use powerful Programmable input and output ports and internal programmable logic to achieve automated pump control system. Instead of the conventional engine controller PLC + simple manner ,making the system more stable and reliable;
- ❖ Air compressor industry applications: Close voltage measurements protection, according to the need to configure programmable analog input, overload protection , with programmable digital inputs, complete startup control, temperature and pressure control, protection parameter settings.

Fully functional, and can detect almost all the generating units of electrical parameters and non-electrical parameters

Mains

Line voltage Uab, Ubc, Uca
Phase voltage Ua, Ub, Uc
Frequency Hz

Gens

Line voltage Uab, Ubc, Uca
Phase voltage Ua, Ub, Uc
Frequency Hz
Load current IA, IB, IC
Each phase and total active power kW
Each phase and total reactive power kVar
Each phase and total apparent power kVA
Each phase and average power factor PF
Accumulate total gens power kWh、kVarh、kVAh

Sensor

Temperature WT °C/°F Choose to display
Oil pressure OP kPa/Psi/Bar Choose to display
Fuel level (FL) %(unit)
Speed (SPD) RPM (unit)
Voltage of Battery(VB) V(unit)
Voltage of Charger(VD) V(unit)
Hour count(HC) can accumulate Max.65535hours
Start times can accumulate Max.65535times

Mains and generator abnormal conditions:

Voltage is too high
Voltage is too low
Frequency is too high
Frequency is too low
Phase loss
Reverse phase
Loss of power

The fault display and protection function project:

High water temperature warn
High water temperature shutdown alarm
Low oil pressure warning
Over speed shutdown alarm
Box high temperature warn
Low fuel level warn
Battery voltage is too high warn
Battery voltage is too low warn
Load over current shutdown alarm
Failed to stop alarm
Emergency stop alarm
Oil pressure sensor open circuit shutdown alarm

4. Order information and modules comparison

4.1. Order information

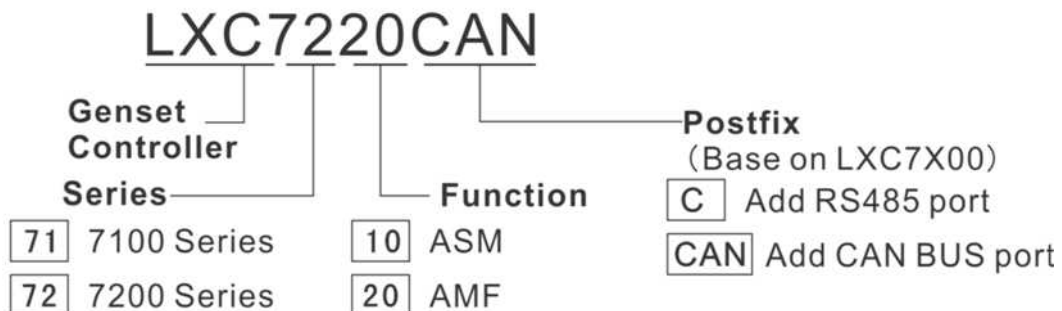

NOTE:

- (1) It is basic model if without postfix.
- (2) Please contact with our qualified personnel for more information about the postfix descriptions.

4.2. Modules comparison

Items	LXC 7220 7920	LXC 7210	LXC 7220C 7920C	LXC 7210C	LXC 7220CAN 7920CAN	LXC 7210CAN	LXC 7120	LXC 7110	LXC 7120C	LXC 7110C	LXC 7120 CAN	LXC 7110 CAN
Input Port	7	7	7	7	7	7	5	5	5	5	5	5
Output port	8	8	8	8	8	8	6	6	6	6	6	6
Sensor number	5	5	5	5	5	5	3	3	3	3	3	3
AMF	•		•		•		•		•		•	
RS485			•	•	•	•			•	•	•	•
GSM SMS control	•	•	•	•	•	•	•	•	•	•	•	•
GPRS Remote monitoring	•	•	•	•	•	•	•	•	•	•	•	•
CAN(J1939)					•	•					•	•
USB	•	•	•	•	•	•	•	•	•	•	•	•
Real-time clock	•	•	•	•	•	•	•	•	•	•	•	•
Event log	•	•	•	•	•	•	•	•	•	•	•	•

4.3. Models abbreviation

Abbreviation	Description
LXC72X0	All LXC7200 series controllers
LXC71X0	All LXC7100 series controllers
LXC7X20	All LXC7200/7100 series AMF controllers
LXC7X10	All LXC7200/7100 series ASM(Auto Start Module) controllers
LXC7920	LXC7920 is dedicated generator controller for the backup power system of base station

NOTE:

- ① Two of the outputs are fixed: start output and fuel output.
- ② LXC7X20/7X10 controller analog sensors are composed by 3 fixed sensors (temperature, pressure, fuel level) and 2 configurable sensors. other controllers analog sensors of three fixed sensors (temperature, pressure, fuel level) .







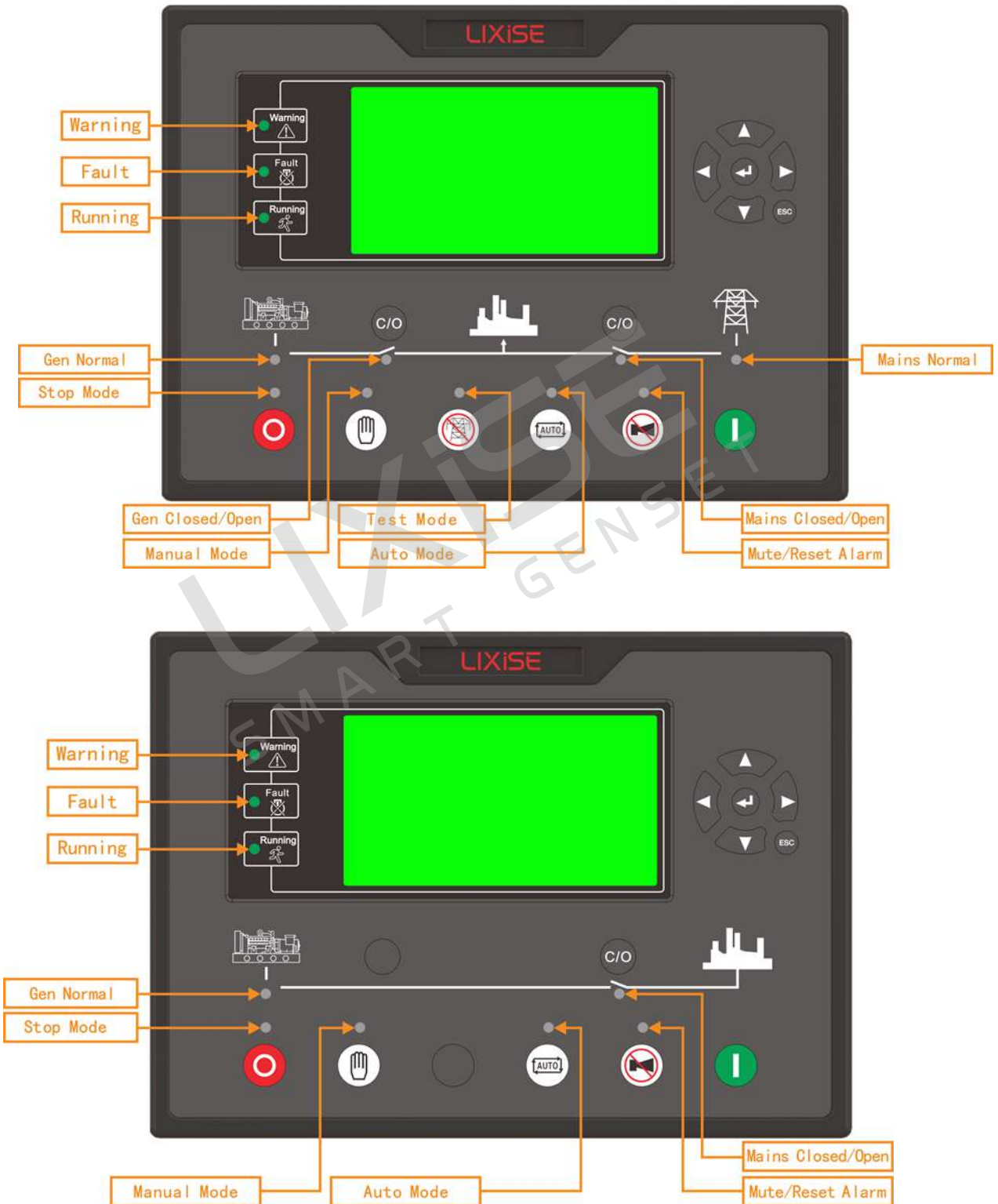







5. Operation









5.1. Indicator light

5.2.





5.2. Key functions

	Stop/Reset	Stop running generator in Auto/Manual mode; Reset alarm in stop mode; During stopping process, press this button again to stop generator immediately.
	Start	Start genset in Manual mode or Manual Testing mode.
	Manual Mode	Press this key and controller enters in Manual mode.
	Auto Mode	Press this key and controller enters in Auto mode.
	Running With Load	Press this key and controller enters in Manual Testing mode. (LXC7X10 without)
	Mute/Reset Alarm	Alarming sound off; If there is trip alarm, pressing the button can reset this alarm. But you can't reset other alarm types
	Gen Closed/Open	Can control generator to switch on or off in manual mode.
	Mains Closed/Open	Can control mains to switch on or off in manual mode.(LXC7X10 without)
	Confirm	1.Set parameters, press Kin can set the parameters. 2.Set parameters, press the Kin can set parameters to confirm. 3.Long press this button, can enter the basic parameter Settings. 4.Press the confirm key and stop key at the same time, can enter the parameter Settings.
	Up/Increase	Up cursor and increase value in setting menu.
	Down/Decrease	Down cursor and decrease value in setting menu.
	Move left	1.Screen scroll. 2.Move the cursor to the left in the set.
	Move right	1.Screen scroll. 2.Move the cursor to the right in the set.
	Quit	1.When the screen displays other parameters, press this key to return to the main screen. 2.Set the parameters, press this key can cancel parameter settings. 3.Enter the parameter setting, long press this button to return to the main screen.

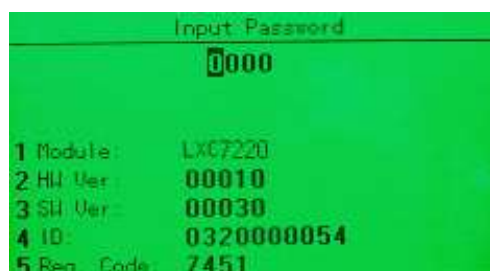
- ✧ **Tips:**In the main interface, press   and from view different interface, press  to return to the main interface.
- ✧ **Tips:**Press  over 3 seconds , go into basic parameters setting menu.
- ✧ **Tips:**Press  and  simultaneously, enter into advanced parameters setting menu if password is correct.
- ✧ **Tips:**default password is 0000, user can change it in event of others change the senior parameters setting. Please closely remember it after changing If you forget your password, please contact our customer service, at the same time press  and  all the information back to the service personnel. (Example, under the figure information)



5.3. LCD DISPLAY

In the main interface, press  and  from the different interfaces, press  to return to the initial page.

Main Interface (Commonly used parameter interface)

(The main interface contains, engine, generator, and status display)

SP	0RPM	L-N	0.0	0.0	0.0 U
OP	++++Kpa	L-L	0.0	0.0	0.0 U
WT	++++ °C	I	0.0	0.0	0.0 A
OL	++++ %	P	0.0	0.0	0.0 KW
BAT	22.8 U	PF	0.000L	F	0.00Hz
Standby					
Remote Invalid			Load Off		
EM STOP					

Engine parameters

Engine Params			
Speed	0 RPM	FuelLevel	++++%
BatVolt	22.8 U	ChargeAlt	0.0U
Dil	++++ Kpa	++++Psi	++++Bar
Temp	++++ °C	++++°F	
Sensor1	++++		
Sensor2	++++		
Number Of Start			0
Engine Run Ti			0:00:00

Load

Load				
	L1	L2	L3	TOT
I	0.0	0.0	0.0	A
P	0.0	0.0	0.0	0.0 KW
Q	0.0	0.0	0.0	0.0Kvar
S	0.0	0.0	0.0	0.0 KVA
PF	0.000L	0.000L	0.000L	0.000L
Gen KW hours				0.0Kwh
Gen KVAh hou				0.0Kvarh

Generator

Generator Freq			0.00Hz
	L1(L1-2)	L2(L2-3)	L3(L3-1)
L-N	0.0	0.0	0.0 U
L-L	0.0	0.0	0.0 U
Phase	0.0	0.0	0.0

Relay Output Status					
OUT1	OUT2	OUT3	OUT4	OUT5	OUT6
↘	↘	↘	↘	↘	↘

Mains Interface (LXC7210 No such interface)

Main Freq			0.00Hz
	L1(L1-2)	L2(L2-3)	L3(L3-1)
L-N	0.0	0.0	0.0 U
L-L	0.0	0.0	0.0 U
Phase	0.0	0.0	0.0

Digital Inputs Status						
IN1	IN2	IN3	IN4	IN5	IN6	IN7
↘	↘	↘	↘	↘	↘	↘

Warning Record

Warning Record					
1/ 39		1970-01-01	00:00:02	Thursday	
SP	0RPM	L-N	0.0	0.0	0.0 U
OP	++++Kpa	L-L	0.0	0.0	0.0 U
WT	++++ °C	I	0.0	0.0	0.0 A
OL	++++ %	P	0.0	0.0	0.0 KW
BAT	22.8 V	PF	0.000L	F	0.00Hz
EM STOP					

Basic configuration parameters

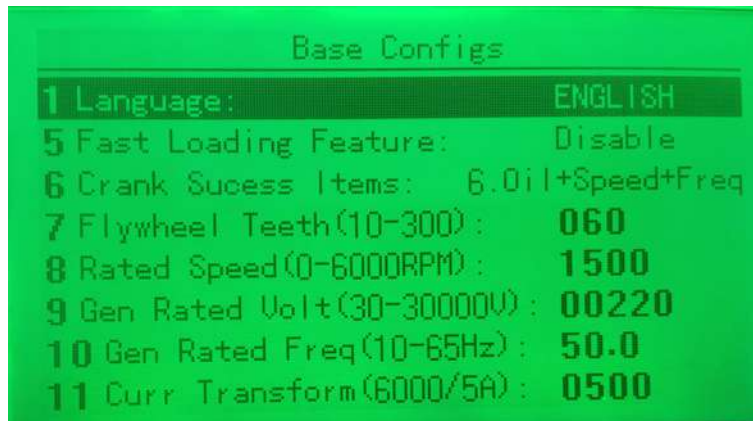

Input Password (Password input interface into the Advanced Configuration)

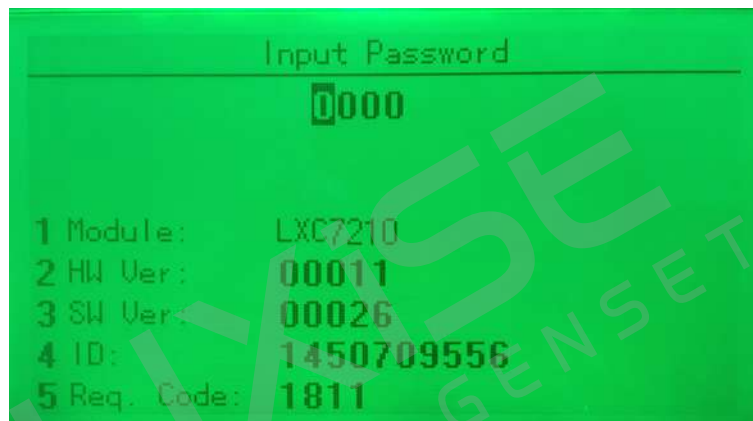

Advanced configuration parameters

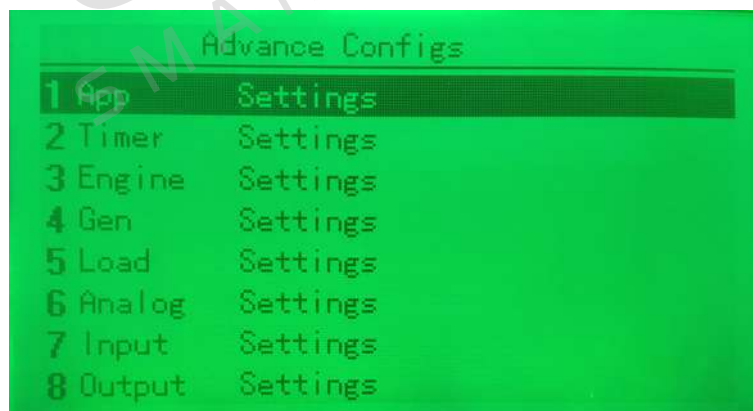



5.4. Basic Parameters setting menu

The basic configuration parameters interface has the following options,press to select up and down the items you need to change, press to enter the selected item to modify the state, press can modify the value, Can shift, Change after press to save the changes.

✧ **Tips:** This series of controllers using a large-screen display, just a basic configuration menu to query and modify all items.

1 Language Selection:	17 Start delay(0-3600s):
2 Mains detection option:	18 Stop delay(0-3600s):
3 Mains rated voltage(30-30000V):	19 Return delay(0-3600s):
4 Mains rated frequency (10-65Hz):	20 Preheat timer(0-3600s):
5 Fast load:	21 Cranking timer(3-60s):
6 Starting conditions for success:	22 Crank Rest Timer (3-60s):
7 Engine Teeth(10-300):	23 Safety on time(0-3600s):
8 Engine rated speed(0-6000RPM):	24 Start idle timer(0-3600s):
9 Gen rated voltage(30-30000V):	25 Warming up timer(0-3600s):
10 Gen rated frequency(10-65Hz):	26 Cooling timer (0-3600s):
11 CT ratio(6000/5A):	27 Stop idle timer(0-3600s):
12 Rated current(5-6000A):	28 ETS(Energize to Stop) hold delay(0-3600s):
13 Rated power(KW):	29 Wait stop delay(0-3600s):
14 Battery Voltage (0-600V):	30 After stop delay (0-3600s):
15 Module date:	31 Controller information:
16 Module time:	

5.5. 1 Advanced Parameters setting menu

Press the  key, enter the correct password to enter the advanced parameters configuration menu, press  to return to the previous menu.

1 Application configuration	9 ATS
2 Timer	10 Mains
3 Engine	11 Module
4 Generator	12 Scheduled
5 Load	13 Maintenance
6 Analog Sensor	14 GSM(SMS)
7 Digital Inputs	15 Controller information
8 Digital Outputs	16 Calibration parameters

6. Start、 stop operation

Press , its indicator lights, and controller enters Auto mode.

6.1. Starting sequence:



- LXC7X20:When Mains is abnormal(over and under voltage, over and under frequency, loss of phase, phase sequence wrong),it enters into "mains abnormal delay"and LCD display count down time. When mains abnormal delay is over, it enter into "start delay";
- LXC7X10:Generator enters into "start delay" as soon as "Remote Start on Load" is active;
- "Start Delay" timer is shown on Status page of LCD.
- When start delay is over, preheat relay outputs (if this be configured), "preheat start delay XX s" is shown in LCD;
- When preheat delay is over, fuel relay outputs 1s and then start relay output; if engine crank fails during "cranking time", the fuel relay and start relay deactivated and enter into "crank rest time" to wait for next crank;



6. If engine crank fails within setting times, the controller sends Fail to Start signal and “Fail To Start” message appears on LCD alarm page;
7. In case of successful crank attempt, “safety on timer” starts. During this period, low oil pressure, high water temperature, under speed, charge failure alarms are disabled. As soon as this delay is over, “start idle delay” is initiated (if configured);
8. During “start idle delay”, under speed, under frequency, under voltage alarms are inhibited. When this delay is over, “warming up delay” starts (if configured);
9. When “warming up delay” is over, if generator state is normal, its indicator will be illuminated. If voltage and frequency has reached on-load requirements, the closing relay will be energised, generator will accept load, generator power indicator will turn on, and generator will enter Normal Running state; if voltage and frequency are abnormal, the controller will initiate alarm (alarm type will be displayed on LCD alarm page).

6.2. Stopping sequence:



1. LXC7X20: when mains return normal during genset running, enters into mains voltage “Normal delay”. When mains normal delay are over, enter into “stop delay”;
2. LXC7X10: When input remote boot failure, began to “stop delay”;
3. When stop delay is over, close generator relay is un-energized; generator enters into “cooling time delay”. After “transfer rest time”, close mains relay is energized. Generator indicator extinguish while mains indicator lights;
4. Idle relay is energized as soon as entering “stop idle delay”;
5. If enter “ETS hold delay”, ETS relay is energized. Fuel relay is deactivated and decides whether generator is stopped or not automatically;
6. Then enter genset “Fail to stop timer”, auto decides whether generator is stopped or not;
7. When the unit is completely stopped, enter the power generation standby mode; if can't stop the alarm controller; (LCD screen displays downtime failure warning) .

6.3. Manual start/stop operation

LXC7X20: Press , controller enters into Manual starts mode and its indicator lights. Press , then controller enters into “Manual Test Mode” and its indicator lights. In the both mode, press  to start generator, can automatically detect crank disconnected, and generator accelerates to high-speed running. With high temperature, low oil pressure and abnormal voltage during generator running, controller can protect genset to stop quickly (please refer to No.4~9 of Auto start operation for detail procedures).

In “manual mode ”, Generator load based on judging the mains is normal, mains is normal, not conversion, load switch mains is unusual, load switch in the power generation side. In “Manual Test Mode ”, generator runs well, whether mains normal or not, loading switch must be transferred to generator side.

6.4. Manual start

LXC7X20: Press , controller enters into Manual starts mode and its indicator lights. Then press  to start generator, can automatically detect crank disconnected, and generator accelerates to high-speed running. With high temperature, low oil pressure and abnormal voltage during generator running, controller can protect genset to stop quickly (please refer to No.4~9 of Auto start operation for detail procedures). After generator runs well, if remote start signal is active, controller will send closing gens signal; if the remote signal is inactive, controller won't send closing signal.

6.5. Manual stop

Press  can shutdown the running generator. (please refer to No.3~7 of Stopping Sequence for

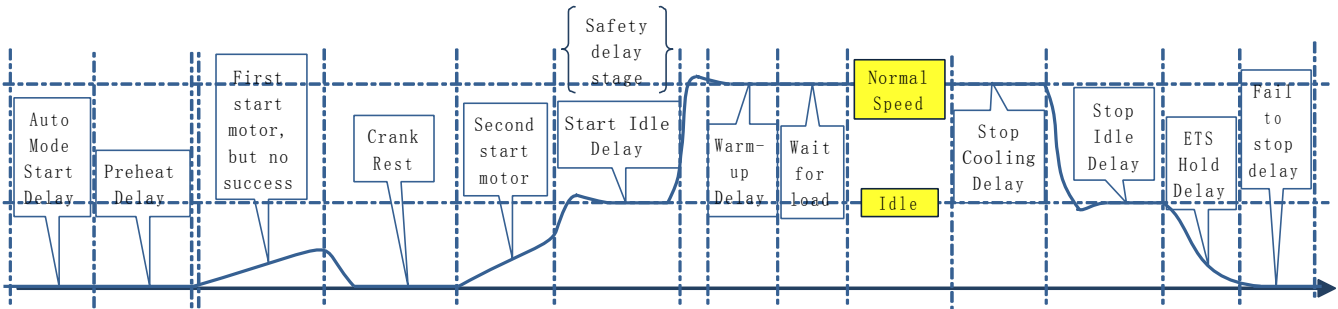

6.6. LXC7X20 Switch control procedures

6.6.1. Manual transfer procedures:

When controller is in Manual mode, the switch control procedures will start through manual transfer. Users Can control the loading transfer of ATS via pressing button to switch on or off. But according to the ATS Switch configuration is different, the specific process have some distinction.

❖ If "Open breaker detect" is "SELECTD is able"

After the press power close break-brake key, according to the current load case in 2processes:

1. generator is opened when the generator is load; If the load is closed, the generator is open;
2. Mains is opened when the mains is load; When the end of the sub-gate delay generator closing;

Press mains close or open key, if mains have taken load, will output unload open; If the load is opened ,the mains close; If the generator is load, the generator to open, when the end of the open delay, then mains to close.

❖ If "Open breaker detect" is " SELECT Enable " and "Closing auxilliary input"

Principles as above, but in every time after closing and break-brake auxiliary input switching state through Testing to determine. If not normal will be closing or opening failure warnings.

Note: This warning can be Resolved by the alarm mute.

6.6.2. Auto transfer procedures:

When controller is in Manual Test, Auto or Stop mode, switch control procedures will start through Automatic transfer.

❖ If "Open breaker detect" is " SELECT Disable " and "Closing auxilliary input"

1. When transferring load from mains to generator, controller begins detecting "fail to transfer" ,then the Open delay and transfer rest delay will begin. When detecting time out, if switch open failed, the generator Will not switch on, otherwise, generator switch on. Detecting transfer failure while gens switch on. When Detecting time up ,if switch on fail, it is need to wait for generator to switch on. If transfer failed and Warning " SELECT Enable" ,there is alarming signal whatever switch on or off failure.

Note :This warning Can be resolved by the alarm mute.

2. Gens to a the mains load, the same principle.

❖ If" Open breaker detect" is "SELECT Disable"

1. Mains load is transferred into generator load, after the delay of switch off and transfer interval, generator switch on. Detecting transfer fail while generator switch on. After detecting time up, if switch on fail, then wait for generator switch on. If transfer fail and warning " SEL Enable", there is alarming signal.

2. Gens to a the mains load, the same principle.

❖ **If input port not configured as Close Mains Auxillary**

Mains load be transferred into gens load, after switch off and transfer interval delay, gens switch on. The way to transfer gens load to mains load is as same as above.

6.7. LXC7X10 Switch control procedures

6.7.1. Manual transfer procedures:

When controller is in Manual mode, manual transfer will be executive. Users can control switch on or off by pressing key. Press generator switch on or off key, if generator have taken load, will output unload signal; if taken no load, generator will output load signal.

6.7.2. Auto control procedures:

When controller is in manual test, auto or stop mode, switch control procedures will start auto transfer.

❖ **If input port is configured as Close Mains Auxillary**

1. If “Open breaker detect” is “SELECT Disable”

Gens load is transferred into generator un-load, after the delay of switch off, detecting transfer failure while switch off output. When detecting time up, if switch off failed, to wait for switch off. Otherwise, switch off is completed. Gens unload is transferred into gens load, after the delay of switch on, detecting transfer failure while switch on outputting. When detecting time up, if switch on failed, to wait for switch on. Otherwise, switch on is completed.

If transfer failed and warning “SEL Enable”, there is alarming signal whatever switch on or off failure.

2. If “Open breaker detect” is “SELECT Enable” Gens load is transferred into gens unload, after the delay of switch off, switch off is completed. Gens unload is transferred into gens load, after the delay of switch on, detecting transfer failure while switch on outputting. When detecting time up, if switch on failed, to wait for switch on. Otherwise, switch on is completed. If transfer failure warning is “SEL Enable”, there is warning signal that “switch on fail”.

❖ **If input port is not configured as Close Mains Auxillary**

Gens un-load is transferred into gens load, gens switch on and output.

Gens load is transferred into gens un-load, gens switch off and output.

▲ NOTE:When using ATS of no interposition, switch off detecting is “SELECT Disable”; When using ATS of having interposition, switch off “SELECT Disable” or “SELECT Enable” both are OK. If choose “SELECT Enable”, switch off output should be configured; When using AC contactor, switch off “SELECT Disable” recommended.

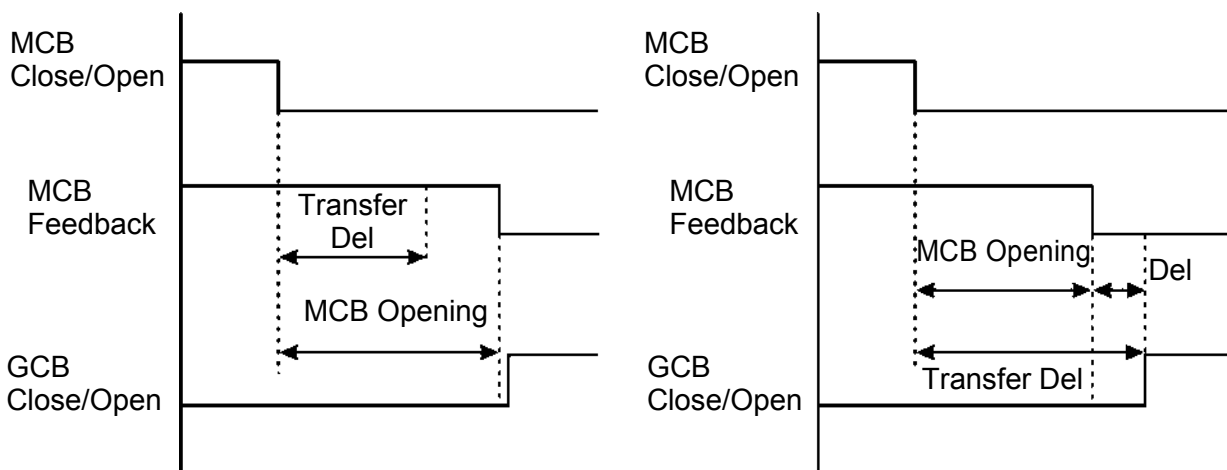

7. SMS Remote control、 wireless remote control function description

GSM Remote control

SMS Code is described as follows

▲ Note:If the operation of the controller, the controller internally set to fly letter phone number can not start with a "+86"

▲ Note:Write text messages are not case sensitive, but must be written in strict accordance with the instructions in the format, the spaces between all the words are a bit of spaces, all commands have to wait until the return code indicates that the operation is valid only.

NO.	SMS Command	SMS return information	Description
1	SMS GENSET	GENSET ALARM	When genset is stopping to alarm
		SYSTEM IN STOP MODE GENSET AT REST	At rest status in stop mode
		SYSTEM IN MANUAL MODE GENSET AT REST	At rest status in stop mode
		SYSTEM IN TEST MODE GENSET AT REST	At rest status in stop mode
		SYSTEM IN AUTO MODE GENSET AT REST	At rest status in stop mode
		SYSTEM IN STOP MODE GENSET IS RUNNING	Running status in stop mode
		SYSTEM IN MANUAL MODE GENSET IS RUNNING	Running status in stop mode
		SYSTEM IN TEST MODE GENSET IS RUNNING SYSTEM IN AUTO MODE GENSET AT RUNNING	Running status in stop mode Running status in stop mode
2	SMS START	GENSET ALARM	Generator is shutdown alarm or trip alarm
		GENSET IS RUNNING	The generator is running
		SMS START INHIBIT	SMS boot prohibited
		STOP MODE NOT START	Cannot start in stop mode
		SMS START OK	Start in manual or auto mode
		AUTO MODE START OK	Can start in auto mode
3	SMS STOP IN AUTO MODE	AUTO MODE STOP OK	In automatic mode shutdown
4	SMS STOP MODE	SMS STOP OK	Set as stop mode
5	SMS MANUAL MODE	SMS MANUAL MODE OK	Set as manual mode
6	SMS TEST MODE	SMS TEST MODE OK	Set as trial test mode
7	SMS AUTO MODE	SMS AUTO MODE OK	Set as auto mode
8	SMS INHIBIT START	INHIBIT START OK	Set as start inhibit
9	SMS PERMIT START	PERMIT START OK	Set as start permit
10	SMS DETAIL	Users check setting (As shown below)	Users can query through a text message multiple generators.

7.1. LXI680 connection diagram

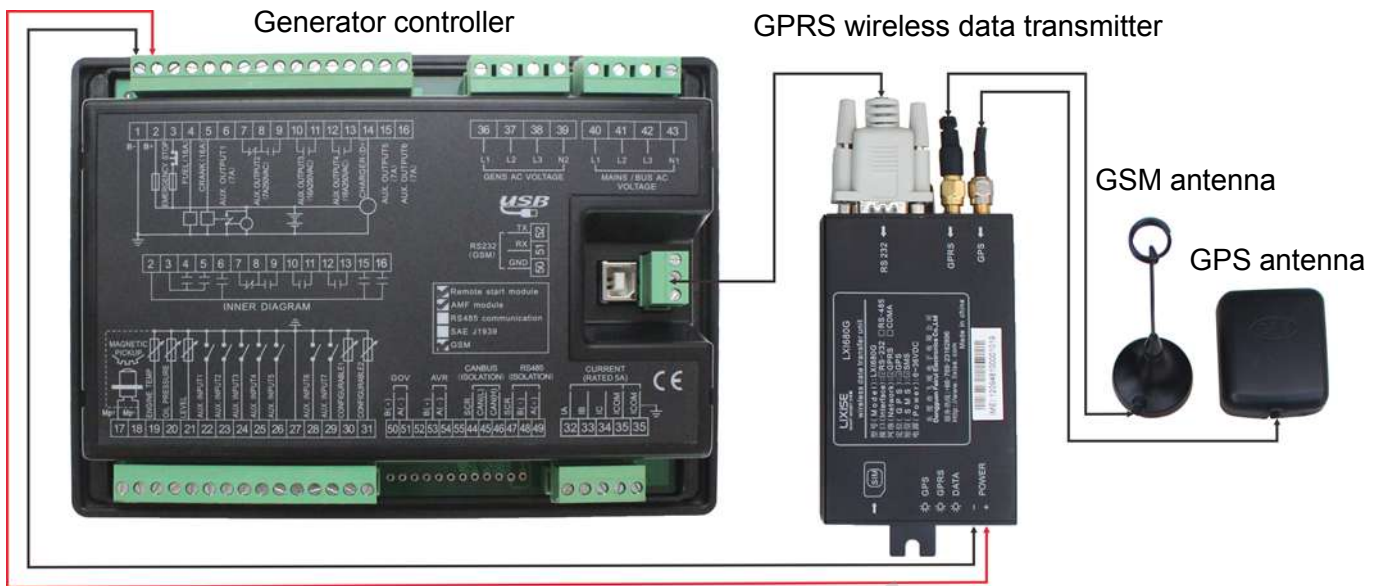

7.2. GSM alarm setting

As show below 【need to the SMS automatically notify the alarm】 When the user check the condition occurs, the DUT module will automatically send SMS to the user set the cell phone number.

GSM Setting

GSM Enable

Activate Phone No.	Description
<input checked="" type="checkbox"/> Phone N.O. +8613612345689	Please input station info, e.g. 3# gen-sets in the eastern district
<input type="checkbox"/> Phone N.O.	
<input type="checkbox"/> Phone N.O.	
<input type="checkbox"/> Phone N.O.	
<input type="checkbox"/> Phone N.O.	

Choose Item For Message Informing When Warning 2

<input checked="" type="checkbox"/> Over Speed Warn	<input type="checkbox"/> Bat High Warn	<input type="checkbox"/> High Temp Warn	<input type="checkbox"/> Sensor 1 Low Warn	<input type="checkbox"/> Input6 Warn
<input type="checkbox"/> Under Speed Warn	<input type="checkbox"/> Bat Low Warn	<input type="checkbox"/> Low Temp Warn	<input type="checkbox"/> Sensor2 Open Circuit	<input type="checkbox"/> Input7 Warn
<input type="checkbox"/> Loss Of Speed	<input type="checkbox"/> Maintenance Due Warn	<input type="checkbox"/> Oil Sensor Open Circu	<input type="checkbox"/> Sensor2 High Warn	<input type="checkbox"/> Main Normal
<input type="checkbox"/> Gens Over Freq Warn	<input type="checkbox"/> Reverse Power Warn	<input type="checkbox"/> High OP Warn	<input type="checkbox"/> Sensor2 Low Warn	<input type="checkbox"/> Main Fail
<input type="checkbox"/> Gens Low Freq Warn	<input checked="" type="checkbox"/> Over Power Warn	<input checked="" type="checkbox"/> Low OP Warn	<input type="checkbox"/> GSM Communicate Fa	<input type="checkbox"/> Generator Start
<input type="checkbox"/> Gens Over Voltage Wa	<input type="checkbox"/> ECU Warn	<input type="checkbox"/> Fuel Open Shutdown	<input type="checkbox"/> Input1 Warn	<input type="checkbox"/> Generator Stop
<input type="checkbox"/> Gens Low Voltage Wa	<input type="checkbox"/> Gens Freq Loss Warn	<input type="checkbox"/> Fuel High Warn	<input type="checkbox"/> Input2 Warn	<input type="checkbox"/> Mains Onload
<input checked="" type="checkbox"/> Over Current	<input type="checkbox"/> Gens Reverse Phase	<input type="checkbox"/> Fuel Low Warn	<input type="checkbox"/> Input3 Warn	<input type="checkbox"/> Gens Onload
<input type="checkbox"/> Failed To Stop	<input type="checkbox"/> ATS Convert Fail	<input type="checkbox"/> Sensor 1 Open Circuit	<input type="checkbox"/> Input4 Warn	<input type="checkbox"/> Not At Auto Mode
<input type="checkbox"/> Charge alternator failur	<input type="checkbox"/> Temp Open Shutdown	<input type="checkbox"/> Sensor 1 High Warn	<input type="checkbox"/> Input5 Warn	<input type="checkbox"/> In Auto Mode

Select All Default Cancel All

Choose Item For User's Message Query 1

<input checked="" type="checkbox"/> Works Mode	<input checked="" type="checkbox"/> Mains freq	<input type="checkbox"/> Load PF	<input checked="" type="checkbox"/> Oil Press(OP)	<input type="checkbox"/> Total Run Hour
<input type="checkbox"/> Mains Volt	<input checked="" type="checkbox"/> Gens Freq	<input type="checkbox"/> Battery Volt	<input checked="" type="checkbox"/> Fuel Level	<input type="checkbox"/> Engine State
<input type="checkbox"/> Gens Volt	<input type="checkbox"/> Load KW	<input type="checkbox"/> Charge Volt(D+)	<input type="checkbox"/> Speed	<input type="checkbox"/> Alarm State
<input type="checkbox"/> Load Current	<input type="checkbox"/> Load KVA	<input type="checkbox"/> Water Temperature(WT)		

Select All Default Cancel All

7.3. Based on the GPRS DTU remote online monitoring

The scheme is based on LXI680G provide wireless data transmission network, remote control operation of the generator on the Internet; and through the increase in the generator controller LXI680G Room communication protocol, so that the controller can the use of LXI680G SMS via SMS to control the generator run and generators receive alarm SMS.

Remark : LXI680G is **Dongguan Feirui Electronics Co.,Ltd** designed tailor-made for the generator controller wireless data transmission module, in particular to optimize the data exchange between the controller and the DTU, truly a fast and reliable data transmission.

Brief introduction:LXI680G is an industrial grade with GPS global satellite positioning function GPRS DTU product. The product integrates a high-performance, low-power industrial-grade GPS module and GPRS module, GPS global positioning technology and GPRS wireless communication technology the perfect combination of a product.

LXI680G platform based on ARM and embedded operating system, built-in industrial-grade module, it can be used in harsh environments, working temperature range can be up to -40°C ~ + 85°C.LXI680G provide standard RS232 serial interface, can be quickly and PLC, industrial control, instruments, meters, RTU equipment is linked together, through the GPRS network will be linked to LXI680G equipment data transmission to a host on the Internet, realize the data remote transparent transmission, at the same time to the front-end equipment of GPS location information reported to host, realize positioning of the equipment.

LXI680G with positioning, wireless data communications and data processing capabilities in a compact, rugged, reliable, easy to install, can be widely used in construction, transportation and other industries. Particularly suitable for tower crane monitoring, heavy machinery management, but also can be used in the field of taxi operations management, transport vehicles, special vehicles, vehicle rental management and leasing.

7.4. Wireless connection schematic diagram

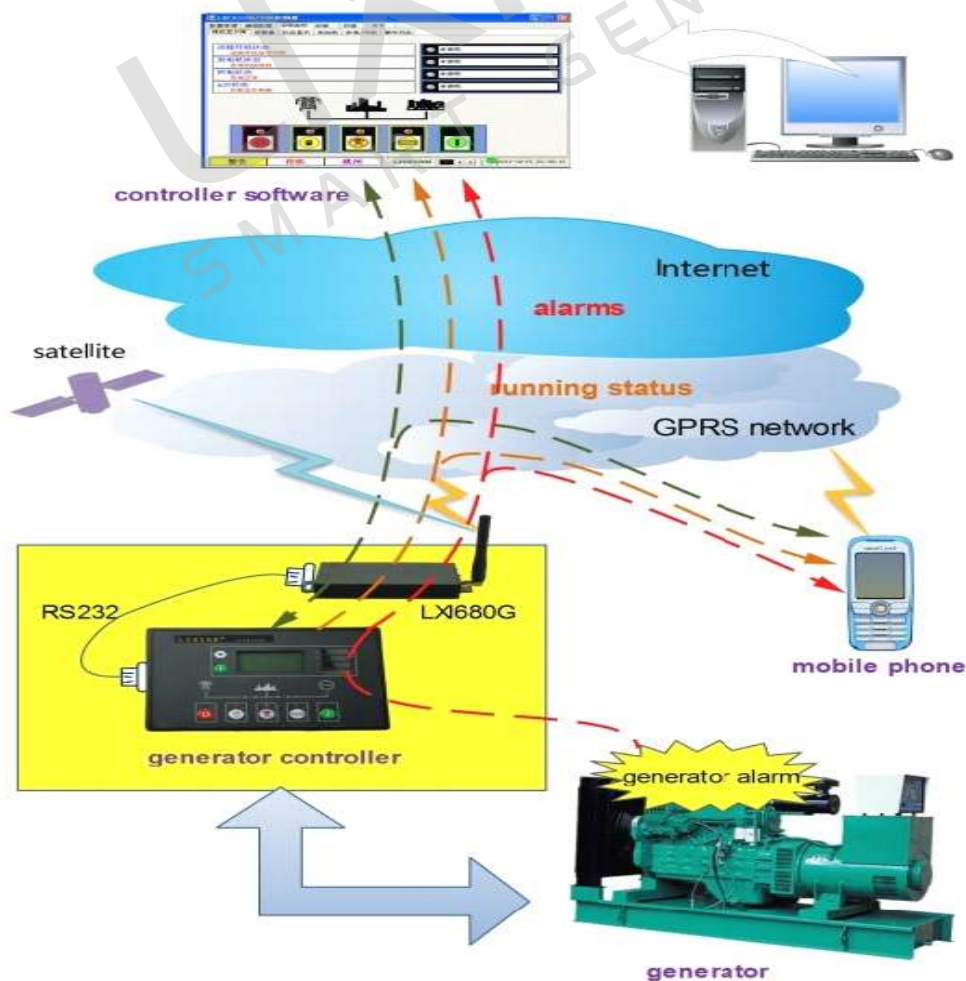

7.5. Connect the controller through the DTU remote

As shown below, Choice in the mode of connection 【 Connected by a data center 】 Can through the Internet remote monitoring state of generator.Details see monitoring software manual.

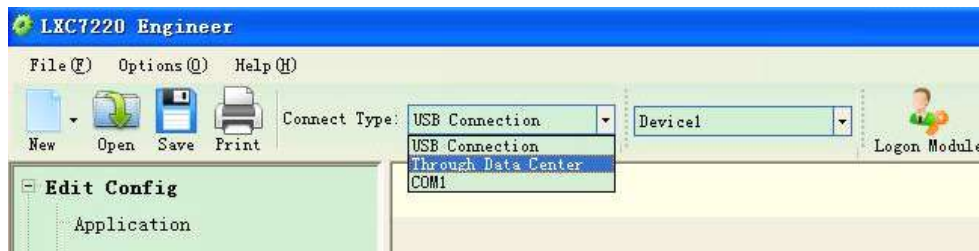

7.6. DTU with the binding of the controller

Controller and LXI680G after binding, it is only through the password to unbundling, if forced the controller and the DTU apart, the controller will record the alarm and displayed on the LCD panel and the warning information, or refuse the next start generator (the user can set up the binding deal) after failure, this feature is especially suitable for generator leasing industry.

7.7. Multilevel password management

Users need to configure the parameters, through different permissions password input, the parameters of the controller will present different configuration interface.

No.	Password type	Extend of competence	Password modification	Unbound	Parameter configuration	Password Managers	Deadline
1	manager	All change permissions (dynamic password Based on the password And the application code For calculating income)				Leasing companies	Long time
2	technician	Only have the parameter Configure permissions (not can unbound)				Leasing Companies Client	Long time
3	Dynamic password	Disposable(only has a one-time password Parameter configure permissions,and unbound)can't change password				Dynamic calculations (Dynamic code Provided by the customer	Certain time effectively

Module password

Alter Module Password(4 digits)

New Engineer Pwd:

New Technician Pwd:

New Operator Pwd:

Binding/Unbinding

If bound DTU was removed: Alertion Gens rejects to boot next time

Generate Dynamic Password

Engineer Password(4 digits)

Request code Dynamic Password

8. History query

8.1.1. Event log

In the control panel buttons to view controller before abnormal downtime record, including the time of the outage warning content display and the state, the controller can record 142 abnormal downtime record recently.

8.1.2. Historical alarm data query

Generator controller will fail instantly record all monitoring parameters, users can remotely view or download, user analyze the cause, because a single record of data is very large, the controller can see the main part of the parameters, other parameters need to access via PC connection . If you need remote access monitoring software through GPRS wireless remote access to data.

History data display window

The screenshot shows a detailed monitoring interface with the following sections:

- Gens:** Displays voltage (L1, L2, L3) and phase differences (L1-2, L2-3, L3-1) for both Frequency and Phase Diff.
- Mains:** Similar to Gens, showing voltage and phase differences.
- Load:** Shows Current (A) for L1, L2, L3 and Active Power (kW), Apparent Power (kVA), and Reactive Power (kVar) for L1, L2, L3, and Total.
- Digital Input Status:** Lists 7 digital inputs with their current status (e.g., Not Used).
- Relay Output Status:** Lists 6 relay outputs (Fuel, Start) with their current status.
- Engine and Sensor Information:** Shows Coolant Temperature, Oil Pressure, Engine Speed, Fuel Level, Aux Sensor 1/2, Battery Voltage, and Charge Alt Voltage.
- Accumulations and Module Info:** Shows Active Energy, Reactive Energy, Run Hours, Number Of Start, and Module Datetime.
- Warning/Shutdown:** Lists various warning and shutdown events.
- Electrical trip/Trip:** Sections for recording electrical and engine trips.

9. Protection

9.1. Shutdown alarm

When controller detects shutdown alarm, it will send signal to stop the generator.
Shutdown alarms as following:

No.	Type	Description
1	Emergency Stop	When controller detects emergency stop signal, it will send a stop signal.
2	Over Speed	When controller detects the speed value is higher than the set value, it will send a stop signal.
3	Under Speed	When controller detects the speed value is lower than the set value, it will send a stop signal.
4	Loss Of Speed Signal	When controller detects speed value equals to 0, and the action select "Shutdown", it will send a stop alarm signal.
5	Over Frequency	When controller detects the frequency value is higher than the set value, it will send a stop signal.
6	Under Frequency	When controller detects the frequency value is lower than the set value, it will send a stop signal.
7	Over Voltage	When controller detects the voltage value is higher than the set value, it will send a stop signal.
8	Under Voltage	When controller detects the voltage value is lower than the set value, it will send a stop signal.
9	Fail To Start	If genset start fail within setting of start times, controller will send a stop signal.
10	Over Current	When controller detects the current value is higher than the set value, it will send a stop signal.
11	Current Negative Phase Sequence Shutdown	When the generator current between three-phase load imbalance is greater than the set value, and generating an alarm and shutdown.
12 - 14	Maintenance1-3 Shutdown	When count down time is 0 and the action select "Shutdown", it will send a stop alarm signal.
15	Reverse Power Shutdown	When controller detects reverse power value (power is negative) is lower than the set value, and the reverse power action select "shutdown", it will send a stop alarm signal.
16	Over Power Shutdown	When controller detects reverse power value (power is positive) is higher than the set value, and the reverse power action select "shutdown", it will send a stop signal.
17	Temp. Sensor Open	When controller detects sensor is open circuit, and the action select "shutdown", it will send a stop signal.
18	High Temp Shutdown	When controller detects temperature is higher than the set value, it will send a stop signal.
19	Pressure Sensor Open	When controller detects sensor is open circuit, and the action select "shutdown", it will send a stop signal.
20	Low OP Shutdown	When controller detects oil pressure is lower than the set value, it will send a stop signal.
21	Level Sensor Open	When controller detects sensor is open circuit, and the action select " shutdown", it will send a stop signal.

22	Low Level Shutdown	When controller detects level is lower than the set value, it will send a stop signal.
23	Flexible Sensor 1 Open	When controller detects sensor is open circuit, and the action select “shutdown”, it will send a stop signal.
24	Flexible Sensor 1 High	When controller detects the sensor value is higher than the max. set value, it will send stop signal.
25	Flexible Sensor 1 Low	When controller detects the sensor value is lower than the min. set value, it will send stop signal.
26	Flexible Sensor 2 Open	When controller detects sensor is open circuit, and the action select “shutdown”, it will send a stop signal.
27	Flexible Sensor 2 High	When controller detects the sensor value is higher than the max. set value, it will send stop signal.
28	Flexible Sensor 2 Low	When controller detects the sensor value is lower than the min. set value, it will send stop signal.
29	Digital Input Port 1-7	When digital input port 1-7 is set as shutdown, and the action is active, it will send a shutdown signal.
30	D + Open shutdown	Generator starting on the D+ connected to detect if an alarm when open.

9.2. Trip and stop alarm

When controller detects shutdown alarm signal, it will shutdown generator quickly and stop after high speed cooling.

Trip and stop alarm as following:

Trip and stop alarm		
No.	Type	Description
1	Over Current	When controller detects the value is higher than the set value, and the action select “trip and shutdown”, it will send trip and stop signal.
2	Current Negative Phase Sequence	When the generator is three-phase load imbalance between the current and larger than the set value, generating a trip and downtime.
3	Maintenance1-3	When count down time is 0 and the action select “trip and shutdown”, it will send a trip and stop signal.
6	Reverse Power	When controller detects reverse power value (power is negative) is lower than the set value, and the action select “trip and shutdown”, it will send a trip and stop signal.
7	Over Power	When controller detects the over power value (power is positive) is higher than the set value, and the action select “trip and shutdown”, it will send a trip and stop signal.
8	Low Fuel	When a trip is generated when the fuel level is low and shut down.
9	Digital Input Ports 1-8	When digital input port1-8 is set as “trip and shutdown”, and the action is active, it will send a trip and stop signal.

9.3. Trip alarm

When controller detects trip alarm, it will break close generator signal quickly, but genset not stop. Trip alarm as following:

Trip alarm		
No.	Type	Description
1	Over Current	When controller detects the value is higher than the set value, and the action select "trip", it will send trip signal.
2	Current Negative Phase Sequence	hen the generator 3 phase load current is greater than the set value of balance and a trip but non-stop.
3	Reverse Power	When controller detects reverse power value (power is negative) is lower than the set value, and the action select "trip", it will send a trip signal.
4	Over Power	When controller detects the over power value (power is positive) is higher than the set value, and the action select "trip", it will send a trip signal.
5	Low Fuel	When the generator current between three-phase load imbalance is greater than the set value, and generating a trip is not shut down.
6	Digital Input Ports1-7	When digital input port1-7 is set as "trip", and the action is active, it will send a trip signal.

9.4. Warnings

When controller detects the warning signal, alarm only and not stop genset. Warnings as following:

Warnings		
No.	Type	Description
1	Over Speed Warn	When controller detects the speed is higher than the set value, it will send warn signal.
2	Under Speed Warn	When controller detects the speed is lower than the set value, it will send warn signal.
3	Loss of Speed Signal Warn	When controller detects the speed is 0 and the action select "Warn", it will send warn signal.
4	Over Frequency Warn	When controller detects the frequency is higher than the set value, it will send warn signal.
5	Under Frequency Warn	When controller detects the frequency is lower than the set value, it will send warn signal.
6	Over Voltage Warn	When controller detects the voltage is higher than the set value, it will send warn signal.
7	Under Voltage Warn	When controller detects the voltage is lower than the set value, it will send warn signal.
8	Over Current Warn	When controller detects the current is higher than the set value, it will send warn signal.
9	Current Negative Phase Sequence Warn	When the generator is an imbalance between the three phase load current and greater than the set value only a warning.
10	Fail to Stop	When generator not stops after the "stop delay" is over.
11	Charge Alt Fail	When controller detects the charger voltage is lower than the set value, it will send warn signal.
12	Battery Over Voltage	When controller detects the battery voltage is higher than the set value, it will send warn signal.
13	Battery Under Voltage	When controller detects the battery voltage is lower than the set value, it will send warn signal.

14	Maintenance1-3 warn	When count down time is 0 and the action select "Warn", it will send warn signal.
17	Reverse Power	When controller detects the reverse power value (power is negative) is lower than the set value, it will send warn signal.
18	Over Power	When controller detects the reverse power value (power is positive) is higher than the set value, it will send warn signal.
19	Gen Loss of Phase	When controller detects the generator loss phase, it will send warn signal.
20	Gen Phase Sequence Wrong	When controller detects the reverse phase, it will send warn signal.
21	Gen load Close Fail	When the controller gen start closing state input is detected, the default close delay is not detected,the issue of closing failure warning. This warning does not automatically eliminated. (You can press the mute button to eliminate)
22	Main Load Close Fail	When the controller main start opening state input is detected, the default open delay is not detected,the issue of opening failure warning.This warning does not automatically eliminated.(You can press the mute button to eliminate)
23	Gen Load Open Fail	When the controller gen start opening state input is detected, the default open delay is not detected,the issue of opening failure warning.This warning does not automatically eliminated.(You can press the mute button to eliminate)
24	Main Load Open Fail	When the controller main start opening state input is detected, the default open delay is not detected,the issue of opening failure warning.This warning does not automatically eliminated.(You can press the mute button to eliminate)
25	Temp. Sensor Open	When controller detects the sensor is open circuit, and the action select "warn", it will send warn signal.
26	High Temp. Warn	When controller detects the temperature is higher than the set value, it will send warn signal.
27	Low Temp. Warn	When controller detects the temperature is lower than the set value, it will send warn signal.
28	Oil Pressure Sensor Open	When controller detects the sensor is open circuit, and the action select "warn", it will send warn signal.
29	Low OP Warn	When controller detects the oil pressure is lower than the set value, it will send warn signal.
30	Level Sensor Open	When controller detects the sensor is open circuit, and the action select "warn", it will send warn signal.
31	Low Level Warn	When controller detects the oil lever is lower than the set value, it will send warn signal.
32	Flexible Sensor 1 Open	When controller detects the sensor is open circuit, and the action select "warn", it will send warn signal.
33	Flexible Sensor 1 High	When controller detects the sensor value is higher than the max. set value, it will send warn signal.
34	Flexible Sensor 1 Low	When controller detects the sensor value is lower than the min. set value, it will send warn signal.
35	Flexible Sensor 2 Open	When controller detects the sensor is open circuit, and the action select "warn", it will send warn signal.
36	Flexible Sensor 2 High	When controller detects the sensor value is higher than the max. set value, it will send warn signal.
37	Flexible Sensor 2 Low	When controller detects the sensor value is lower than the min. set value, it will send warn signal.
38	Digital Input 1-7 Warn	When digit input port 1-7 is set as warning and active, controller sends corresponding warning signal.
45	DTU Bonding Fail	When Set DTU binding, the controller and the DTU communication failure display instructions.

10. Wirings connection

LXC72X0 , LXC71X0, LXC7920 controller's rear as following:

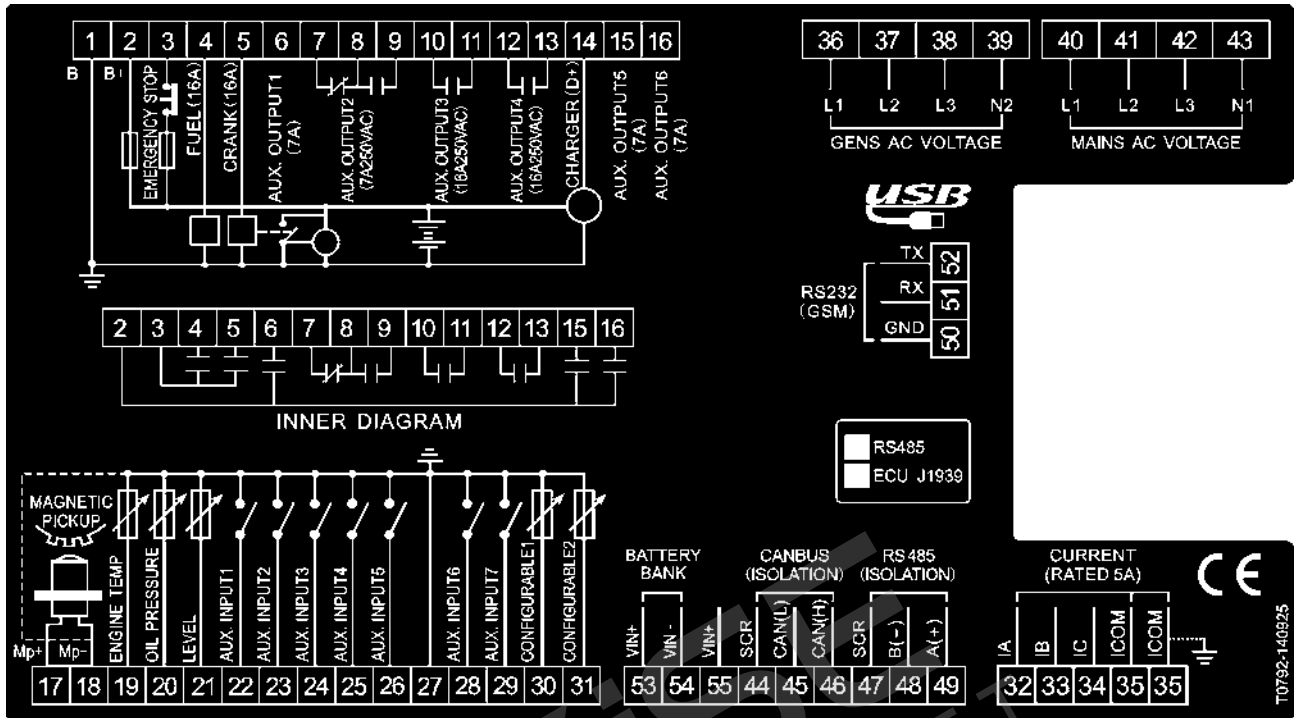

No.	Functions	Diameter	Remark
1	DC input B-	2.5mm	DC Power Supply negative input,external starter battery's negative.
2	DC input B+	2.5mm	DC Power Supply positive input of the the external starter battery positive, it is recommended to use 20A fuse.
3	Emergency stop	2.5mm	DC voltage through the emergency stop button connected equipment supplied to the fuel and starter relay output, recommended maximum 30A fuse.
4	Fuel relay output	1.5mm	By the 3-terminal DC voltage supply, rated current 16A
5	Start relay output	1.5mm	By the B + supply output Rated current 7A
6	Aux. Output 1	1.5mm	Normally closed:Rated current 7A
7	Aux. Output 2		Common point
8			Normally closed:Rated current 7A
9			
10-13	Aux. Output 3-4	2.5mm	Normally open passive contacts of relay, rated 16A, passive contact
14	Charge generator D+ port input	1.0mm	Connected to charging starter s D+ (WL) terminals. If there is no this terminal, and be hung up.
15	Aux. Output 5	1.5mm	By the B + supply output Rated current 7A (LXC7X10 without)
16	Aux. Output 6	1.5mm	
17	Magnetic pickup		Connected to Magnetic Pickup, shielding line is recommended
18	Magnetic pickup input, and controller inner be connected to battery negative.		Common ground, which can be accessed chassis or starter battery negative

19	Temperature sensor input		Connected to temp. Sensor
20	Oil pressure sensor input		Connected to oil pressure sensor
21	Oil level sensor input		Connected to oil level sensor
22-26	Aux input 1-5	1.0mm	Ground connected is active (B-)
27	Public terminals of sensor		Public terminals of sensor, controller inner are connected to battery negative.
28-29	Aux input 6-7	1.0mm	Ground connected is active (B-) (LXC7X10 without)
30	Configurable sensor 1		Connected to temperature, oil Pressure or fuel level sensors (LXC7X10 without)
31	Configurable sensor 2		
32	CT A-phase sensing input	1.5mm	Outside connected to secondary coil of current transformer(rated 5A)
33	CT B-phase sensing input	1.5mm	
34	CT C-phase sensing input	1.5mm	
35	Public terminals of current transformer	1.5mm	
36	Genset A-phase Voltage sensing input	1.0mm	Connected to A-phase output of genset (2A fuse is recommended)
37	Genset B-phase Voltage sensing input	1.0mm	Connected to B-phase output of genset (2A fuse is recommended)
38	Genset C-phase Voltage sensing input	1.0mm	Connected to C-phase output of genset (2A fuse is recommended)
39	Genset N-wire input	1.0mm	Connected to output N-wire of genset
40	Mains A-phase voltage sensing input	1.0mm	Connected to A-phase of mains (2A fuse is recommended) (LXC7X10without)
41	Mains B-phase voltage sensing input	1.0mm	Connected to B-phase of mains (2A fuse is recommended) (LXC7X10without)
42	Mains C-phase voltage sensing input	1.0mm	Connected to C-phase of mains (2A fuse is recommended) (LXC7X10without)
43	Mains N-wire input	1.0mm	Connected to output N-wire of mains(LXC7X10 without)
44	CAN screen	0.5mm	Impedance-120Ω shielding wire is recommended, its single-end earthed. (controllers without RS485 don't have this terminal)
45	CAN(L)	0.5mm	
46	CAN(H)	0.5mm	
47	RS485 screen	0.5mm	
48	RS485-	0.5mm	
49	RS485+	0.5mm	
50	RS232 GND	0.5mm	Recommended to use shielded cable, the shield single-grounded (No SMS function controller without these terminals)
51	RS232 RX	0.5mm	
52	RS232 TX	0.5mm	
53	BATTERY BANK VIN+	0.5mm	Connected to V+ of backup battery in base station.(Only for LXC7921)
54	BATTERY BANK VIN-	0.5mm	Connected to V- of backup battery in base station.(Only for LXC7921)
55	VIN+	0.5mm	Connected to direct voltage detecting port (0~80VDC).(Only for LXC7921)

Back panel terminal block wiring description:

✧ **NOTE:** Back USB interface for programming interface parameters, can be directly using a computer programming of the USB cable to the controller, the controller without external power supply.

⚠NOTE: Prohibited during operation of the engine starter batteries removed, otherwise it will cause the control system due to excessive DC input voltage and burned!

11. Parameters setting

11.1. Basic configuration parameters

NOTE: LXC7X10controller no items of mains in setting and also no mains items in configurable ports of input/output.

NOTE: Please set the generator frequency value as low as possible when cranking, in order to make the starter be separated quickly as soon as crank disconnect.

















CAUTION: Please change the controller parameters when generator is in stand-by mode only otherwise, alarming to stop and other abnormal conditions may happen.

In the parameter display long press for more than 3 seconds  key,you can enter the basic parameters of the configuration interface.

Basic configuration parameter			
No.	Items	Defaults	Description
1	Language Selection:	Chinese	The controller display language set
2	Mains detect Options:	Enable	The mains condition monitoring settings
3	Mains Rated Voltage (30-30000V):	00230	Standard for checking mains over/under voltage. (This value is primary voltage of transformer).
4	Mains Rated Freq (10-65Hz):	50.0	Standard for checking mains over/under frequency.
5	Quick load:	Ban	
6	Crank Disconnect	6.Oil pressure + speed + generator	Conditions of disconnecting starter with engine. Each condition can be used alone and simultaneously.
7	Flywheel Teeth(10-300):	118	Teeth number of the engine for judging of starter disconnection and inspecting speed of engine.
8	Rated Speed (0-6000RPM):	1500	Offer standard to judge over /under/ loading speed.
9	Gen Rated Volt (30-30000V):	00230	Offer standards for detecting of gens' over/under voltage and loading volt.If using voltage transformer, this value is primary volt of transformer.
10	Gen Rated Freq (10-65Hz):	50.0	Offer standards for detecting of over/ under /load frequency.
11	Curr Transform (6000/5A):	0500	The change of external connected CT.
12	Rated Current(5-6000A):	0500	Generator's rated current, standard of load current.
13	Rated Power(KW):	0276	Generator's rated power, standard of load current.
14	Battery Rated Volt (0-600V):	24.0	Standard for detecting of over/under voltage of battery.
15	Module Date:	User Setting	
16	Module Clock:	User Setting	

17	Start Delay (0-3600s):	0003	Time from mains abnormal or remote start signal is active to start genset.
18	Stop Delay (0-3600s):	0003	Time from mains normal or remote start signal is inactive to genset stop.
19	Return Delay (0-3600s):	0003	
20	Preheat Delay (0-3600s):	0005	Time of pre-powering heat plug before starter is powered up.
21	Cranking Time (3-60s):	05	Time of starter power up each time.
22	Crank Rest Time (3-60s):	05	The second waiting time before power up when engine start fail.
23	Safety On Delay (0-3600s):	0005	Alarms for low oil pressure high temp , under speed,under frequency/ voltage , charge fail are inactive.
24	Start Idle Time (0-3600s):	0005	Idle running time of genset when starting.
25	Warming Up Time (0-3600s):	0005	Warming time before genset switch on , after it into high speed running.
26	Cooling Time (0-3600s):	0005	Radiating time before genset stop, after it unloads.
27	Stop Idle Time(0-3600s):	0005	Idle running time when genset stop.
28	ETS Hold Time (0-3600s):	0005	Stop electromagnet's power on time when genset is stopping.
29	Wait Stop Time (0-3600s):	0005	
30	After Stop Time (0-3600s):	0002	
31	Controller information:	Product version information	

11.2. Advanced configuration parameters

In the controller main interface, press  and  key, enter the password input interface, press  or  key to enter the corresponding bit password(0-9), press   shift, after the completion of the input  proofreading password, the password is correct according to the different permissions password to enter the main interface of the parameters of the different permissions, the password error exit. (The factory default password is: 0000) The factory default password the user can modify. Press  and  keys can flip up and down the parameters configuration screen operation, under the currently selected configuration parameter, press the  key, to the current configuration mode parameters, the current value of the first black display, press  or  keys for the bit value adjustment , press   key to shift, press the  keys to confirm the Settings. This value is permanently saved to the internal FLASH controller. Configuration process, press  to return to the previous menu or long press  to exit the configuration menu to return to the main screen .

Advanced configuration parameters					
Items	No.	Items	Default	Description	
Application Settings	1	Immediate Mains Dropout:	Close	This item is related to all kinds of ATS type.	
	2	Main Failure Detection:	Enable	If disabled,controller will not detect Mains state.	
	3	Fast Loading Feature:	Disable	If enabled,the generator immediately load without any delay after booting succeed.	
	4	Alarm Before Crank:	Enable		
	5	Optional Configuration 1-3:			
		5.1 Option:		Disable	
		5.2 Gen AC System:		0. 3P4W	
		5.3 Gen Rated Volt(30-30000V):		230	
		5.4 Gen Rated Freq(10-65Hz):		50	
		5.5 Rated Current(5-6000A):		500	
		5.6 Rated Power(0-6000KW):		276	
		5.7 Rated Speed(0-6000RPM):		1500	
		5.8 Main AC System:		0. 3P4W	
5.9 Main Rated Volt(30-30000V):		230	Standard for checking mains over/under voltage.(It is primary voltage when using voltage transformer).		
5.10 Main Rated Freq(10-65Hz):		50	Standard for checking mains over/under frequency.		
Timer Settings	1	Start Delay(0-3600s):	1	Time from mains abnormal or remote start signal is active to start gen-set.	
	2	Stop Delay(0-3600s):	1	Time from mains normal or remote start signal is inactive to gen-set stop.	
	3	Return Delay(0-3600s):	3		
	4	Preheat Delay(0-3600s):	0	Time of pre-powering heat plug before starter is powered up.	
	5	Cranking Time(1-60s):	8	Time of starter power up.	
	6	Crank Rest Time(3-60s):	10	The waiting time before second power up when engine start fail.	
	7	Safety On Delay(0-3600s):	8	Alarms for low oil pressure, high temperature, under speed, under frequency/voltage, charge fail are inactive.	
	8	Start Idle Time(0-3600s):	0	Idle running time of genset when starting.	
	9	Warming Up Time(0-3600s):	10	Warming time between genset switch on and high speed running.	
	10	Cooling Time(0-3600s):	10	Radiating time before genset stop, after it unloads.	
	11	Stop Idle Time(0-3600s):	0	Idle running time when genset stop.	
	12	ETS Hold Time(0-3600s):	20	Stop electromagnet's power on time when genset is stopping.	
	13	Wait Stop Time(0-3600s):	0	Time between over of genset idle delay and stopped when "ETS time" is set as 0; Time between over of ETS hold delay and stopped when "ETS Hold output time" is not 0.	

	14 After Stop Time(0-3600s):	0	Time between genset stopped and standby.	
	15 Crank Protect Time(0-5s):	3	It used to protect the motor, to prevent the motor stall time is too long and damage.	
	16 Warm Protect Time(0-36s):	10	It refers to the genset after starting from idle to high speed time. When the time set too short will alarm shutdown.	
	17 Up Load Protect Time(0-36s):	10		
Engine Settings	1 Rated Speed(0-6000RPM):	1500	Offer standard to judge over/under/loading speed.	
	2 On Load Speed(0-6000RPM):	1350	Setting value is percentage of rated speed. Controller detects when it is ready to load. It won't switch on when speed is under loading speed.	
	3 Magnetic Pickup:	Enable		
	4 Flywheel Teeth(10-300):	118	Tooth number of the engine, for judging of starter separation conditions and inspecting of engine speed. See the installation instructions.	
	5 Loss Speed Action:	Warn	0: Warn; 1: Shutdown	
	6 Loss Speed Delay(0-3600s):	5	Time from detecting speed is 0 to confirm the action.	
	7 Crank Disconnect Conditions :	7.1 Crank Success Items:	Oil+Speed+Freq	
		7.2 Disconnect Freq(0-65Hz):	12	
		7.3 Disconnect Speed(100-6000RPM):	360	
		7.4 Disconnect Oil(0-1000Kpa):	200	
		7.5 Disconnect D+(3-32V):	3	
		8 Number Of Crank(1-10times):	3	Max. Crank times of crank attempts. When reach this number, controller will send start failure signal.
	9 Over Speed Shoot(0-15%):		The generator set during startup than the rated speed proportion.	
	10 Over Speed Alarm Settings :	10.1 Shutdown Option:	Enable	
		10.2 Shutdown Trip(100-6000RPM):	1710	
		10.3 Shutdown Delay(0-3600s):	2	
		10.4 Pre/alarm Option:	Enable	
		10.5 Pre/alarm Trip(100-6000RPM):	1650	
		10.6 Pre/alarm Return(100-6000RPM):	1620	
		10.7 Pre/alarm Delay(0-3600s):	5	
		11 Engine Under Speed Alarm Settings		
11.1 Shutdown Option:	Enable			
11.2 Shutdown Trip(100-6000RPM):	1200			
11.3 Shutdown Delay(0-3600s):	3			
11.4 Pre/alarm Option:	Enable			
11.5 Pre/alarm Trip(100-6000RPM):	1290			
11.6 Pre/alarm Return(100-6000RPM):	1350			

	11.7 Pre/alarm Delay(0-3600s):	5		
12	Battery Alarm Settings			
	12.1 Bat Rated Volt(1-60V):	24		
	12.2 Over Volt Option:	Enable		
	12.3 Over Volt Trip(1-80V):	28.8		
	12.4 Over Volt Return(1-80V):	27.6		
	12.5 Over Volt Delay(0-3600s):	60		
	12.6 Under Volt Option:	Enable		
	12.7 Under Volt Trip(1-60V):	20.4		
	12.8 Under Volt Return(1-60V):	21.6		
	12.9 Under Volt Delay(0-3600s):	60		
13	Charge Alt Alarm Settings			
	13.1 Pre-alarm Option:	Enable		
	13.2 Pre-alarm Trip(1-60V):	8		
	13.3 Pre-alarm Return(1-60V):	10		
	13.4 Per-alarm Delay(0-3600s):	10		
Generator Settings	1 Rated Volt(30-30000V):	230	To offer standards for detecting of gens over/under voltage and loading voltage. (It is primary voltage when using voltage transformer; it is line voltage when AC system is 3P3W while it is phase voltage when using other AC system).	
	2 On Load Volt(30-30000V):	196	Setting value is percentage of generator rated voltage. When gens voltage under load voltage, won't enter into normally running, during the period of when controller ready to detect loading.	
	3 Rated Freq(10-65Hz):	50	To offer standards for detecting of over/under/load frequency.	
	4 On Load Freq(10-65Hz):	42.5	Setting value is percentage of generator rated frequency. When generator frequency under load frequency, it won't enter into normal running.	
	5 Gen AC System:	0.3P4W		
	6 Gen Poles:	4P	Numbers of generator pole, used for calculating starter rotate speed when without speed sensor	
	7 Loss Of Phase Option:	Enable		
	8 Reverse Phase Option:	Enable		
	9	Volt Transform Settings		
		9.1 Option:	Enable	
		9.2 VT Primary(30-30000V):	100	
		9.3 VT Secondary(30-3000V):	100	
	10	Gen Volt Warning Settings		
		10.1 Over Volt Option:	Enable	Action when generator over voltage warning.
		10.2 Over Volt Trip(0-1500V):	253	
10.3 Over Volt Return(0-1500V):		248		
10.4 Over Volt Delay(0-3600s):		5		
	10.5 Under Volt Option:	Enable	Action when generator under voltage	

			warning.		
		10.6 Under Volt Trip(0-1500V):	193		
		10.7 Under Volt Return(0-1500V):	198		
		10.8 Under Volt Delay(0-3600s):	5		
11	Gen Volt Shutdown Settings				
		11.1 Over Volt Option:	Enable	Action when generator over voltage shutdown.	
		11.2 Over Volt Trip(0-1500V):	276		
		11.3 Over Volt Delay(0-3600s):	3		
		11.4 Under Volt Option:	Enable	Action when generator under voltage shutdown.	
		11.5 Under Volt Trip(0-1500V):	184		
		11.6 Under Volt Delay(0-3600s):	3		
	12	Gen Freq Warning Settings			
		12.1 Over Freq Option:	Enable	Action when generator over frequency shutdown.	
		12.2 Over Freq Trip(10-75Hz):	55		
		12.3 Over Freq Return(10-75Hz):	54		
		12.4 Over Freq Delay(0-3600s):	5		
		12.5 Under Freq Option:	Enable	Action when generator under frequency shutdown.	
		12.6 Under Freq Trip(10-75Hz):	42		
		12.7 Under Freq Return(10-75Hz):	43		
13	Gen Freq Shutdown Settings				
		13.1 Over Freq Option:	Enable	Action when generator over frequency shutdown alarm.	
		13.2 Over Freq Trip(10-75Hz):	57		
		13.3 Over Freq Delay(0-3600s):	2		
		13.4 Under Freq Option:	Enable	Action when generator under frequency shutdown alarm.	
		13.5 Under Freq Trip(10-75Hz):	40		
Load Settings	1	Current Transform(6000/5A):	500	The ratio of external CT.	
	2	Rated Current(5-6000A):	500	Generator's rated current, standard of load current.	
	3	Rated Power(0-6000KW):	276	Generator's rated power, standard of load power .	
	4	Current Neg. Phase Sequence Settings			
			4.1 Option:	Disable	
			4.2 Trip(0-100%):	100	
		4.3 Action:	Warn		
	5	Over Current Settings			
			5.1 Option:	Enable	
			5.2 Action:	Warn	
			5.3 Trip(0-200%):	120	
		5.4 Delay Type:	Fixed Delay		
	5.5 Delay Time Multi(1-36):	10	When the generator set is used in parallel		

			mode, and need to configure, or can be disabled.	
	6	Reverse Power Settings		
		6.1 Option:	Disable	
		6.2 Action:	Warn	
		6.3 Trip(1-100%):	10	
		6.4 Return(1-100%):	5	
	6.5 Delay Time(0-3600s):	5		
	7	Over Load Settings		
		7.1 Option:	Disable	
		7.2 Action:	Warn	
		7.3 Trip(0-200%):	110	
7.4 Return(0-200%):		105		
		7.5 Delay Time(0-3600s):	5	The ratio of external CT.
8	Temp Sensor Settings			
	1.1Curve Type:	VDO 120℃		
	1.2Open Action:	Warn		
1	1.3Temp Shutdown Settings			
	1.3.1 High Option:	Enable		
	1.3.2 High Trip(0-140℃):	98		
	1.3.3 High Delay(0-3600s):	3		
	1.4Temp Warning Settings			
	1.4.1 High Option:	Enable		
	1.4.2 High Trip(0-140℃):	95		
	1.4.3 High Return(0-140℃):	93		
	1.4.4 High Delay(0-3600s):	5		
	1.4.5 Low Option:	Disable		
	1.4.6 Low Trip(0-140℃):	70		
	1.4.7 Low Return(0-140℃):	75		
	1.4.8 Low Delay(0-3600s):	5		
	1.5 Temp Heater Settings		When the heating device, this configuration to achieve automatic heating function.。	
	1.5.1 Option:	Disable		
	1.5.2 Turn On Value(-50-140℃):	50		
	1.5.3 Turn Off Value(-50-140℃):	55		
	1.5.4 Delay(0-3600m):	60		
	1.6 Temp Cooler Settings		When the cooling device,this configuration to achieve automatic cooling function.	
	1.6.1 Option:	Disable		
1.6.2 Turn On Value(0-140℃):	80			
1.6.3 Turn Off Value(0-140℃):	75			
1.6.4 Delay(0-3600m):	60m			
1.7 User defined Curve Settings	Ω	℃		
1.7.1 X 000 Y 000	000	163		
1.7.2 X 000 Y 000	032	110		
1.7.3 X 000 Y 000	064	085		

	1.7.4	X 000 Y 000	096	073		
	1.7.5	X 000 Y 000	128	064		
	1.7.6	X 000 Y 000	192	053		
	1.7.7	X 000 Y 000	256	044		
	1.7.8	X 000 Y 000	480	035		
2	Oil Sensor Settings					
	2.1 Curve Type:		VDO 0-10BAR			
	2.2 Open Action:		Warn			
	2.3 Alarm Settings					
	2.3.1 Shutdown Option:		Enable			
	2.3.2 Shutdown Trip(0-999Kpa):		103			
	2.3.3 Shutdown Delay(0-3600s):		5			
	2.3.4 Pre/alarm Option:		Enable			
	2.3.5 Pre/alarm Trip(0-999Kpa):		124			
	2.3.6 Pre/alarm Return(0-999Kpa):		138			
	2.3.7 Pre/alarm Delay(0-3600s):		5			
	2.4 User defined Curve Settings			Ω	KPa	
	2.4.1	X 000 Y 000	000	000		
	2.4.2	X 000 Y 000	016	000		
	2.4.3	X 000 Y 000	032	179		
	2.4.4	X 000 Y 000	048	241		
	2.4.5	X 000 Y 000	064	338		
2.4.6	X 000 Y 000	096	503			
2.4.7	X 000 Y 000	128	703			
2.4.8	X 000 Y 000	176	1034			
3	Fuel Sensor Settings					
	3.1 Curve Type:		1: VDO0-180ohm			
	3.2 Open Action:		Warn			
	3.3 Alarm Settings					
	3.3.1 Option:		Enable			
	3.3.2 Action:		Warn			
	3.3.3 Trip(0-300%):		10			
	3.3.4 Return(0-300%):		15			
	3.3.5 Delay(0-3600s):		5			
	3.4 Fuel Pump Settings				When the fuel pump device, this configuration level to achieve automatic control function.	
	3.4.1 Option:		Disable			
	3.4.2 Turn On Value(0-300%):		10			
	3.4.3 Turn Off Value(0-300%):		80			
	3.4.4 Delay(0-3600s):		60			
	3.5 User defined Curve Settings			Ω	%	
	3.5.1	X 000 Y 000	000	000		
	3.5.2	X 000 Y 000	020	010		
3.5.3	X 000 Y 000	040	020			
3.5.4	X 000 Y 000	080	040			
3.5.5	X 000 Y 000	100	050			

	3.5.6 X 000 Y 000	120 060	
	3.5.7 X 000 Y 000	160 080	
	3.5.8 X 000 Y 000	200 100	
4	Sensor1 Settings		
	4.1 Sensor Type:	Not Used	
	4.2 Curve Type:	VDO 120℃	
	4.3 Open Action:	Warn	
	4.4 Shutdown Settings		
	4.4.1 Sensor 1 High Option:	Disable	
	4.4.2 Sensor 1 High Trip:	98	
	4.4.3 Sensor 1 High Delay:	2	
	4.4.4 Sensor 1 Low Option:	Disable	
	4.4.5 Sensor 1 Low Trip:	8	
	4.4.6 Sensor 1 Low Delay:	2	
	4.5 Warning Settings		
	4.5.1 High Option:	Disable	
	4.5.2 High Trip:	90	
	4.5.3 High Return:	85	
	4.5.4 High Delay:	2	
	4.5.5 Low Option:	Disable	
	4.5.6 Low Trip:	10	
	4.5.7 Low Return:	15	
	4.5.8 Low Delay:	2	
4.6 User defined Curve Settings	Ω $^{\circ}\text{C}$		
4.6.1 X 000 Y 000	000 163		
4.6.2 X 000 Y 000	032 110		
4.6.3 X 000 Y 000	064 085		
4.6.4 X 000 Y 000	096 073		
4.6.5 X 000 Y 000	128 064		
4.6.6 X 000 Y 000	192 053		
4.6.7 X 000 Y 000	256 044		
4.6.8 X 000 Y 000	480 035		
5	Sensor2 Settings		
	5.1 Sensor Type:	Not Used	
	5.2 Curve Type:	VDO 0-10BAR	
	5.3 Open Action:	Warn	
	5.4 Shutdown Settings		
	5.4.1 Sensor 2 High Option:	Disable	
	5.4.2 Sensor 2 High Trip:	20	
	5.4.3 Sensor 2 High Delay:	2	
	5.4.4 Sensor 2 Low Option:	Disable	
	5.4.5 Sensor 2 Low Trip:	8	
	5.4.6 Sensor 2 Low Delay:	2	
	5.5 Warning Settings		
	5.5.1 Sensor 2 High Option:	Disable	
5.5.2 Sensor 2 High Trip:	18		
5.5.3 Sensor 2 High Return:	15		

	5.5.4 Sensor 2 High Delay:	2	
	5.5.5 Sensor 2 Low Option:	Disable	
	5.5.6 Sensor 2 Low Trip:	10	
	5.5.7 Sensor 2 Low Return:	15	
	5.5.8 Sensor 2 Low Delay:	2	
	5.6 User defined Curve Settings	Ω KPa	
	5.6.1 X 000 Y 000	000 000	
	5.6.2 X 000 Y 000	016 000	
	5.6.3 X 000 Y 000	032 179	
	5.6.4 X 000 Y 000	048 241	
	5.6.5 X 000 Y 000	064 338	
	5.6.6 X 000 Y 000	096 503	
	5.6.7 X 000 Y 000	128 703	
	5.6.8 X 000 Y 000	176 1034	
Digital Inputs Settings	Digital Input 1 Settings:		
	1.1 Type:	Remote Start On Load	
	1.2 Active:	Close Valid	
	Digital Input 2 Settings:		
	1.1 Type:	Aux High Temp	
	1.2 Active:	Close Valid	
	Digital Input 3 Settings:		
	1.1 Type:	Aux Low OP	
	1.2 Active:	Close Valid	
	Digital Input 4 Settings:		
	1.1 Type:	User Configured	
	1.2 Active:	Close Valid	
	1.3 Action:	Warn	
	1.4 Period:	From Always	
	1.5 Delay(0-20s):	2	
	Digital Input 5 Settings:		
	1.1 Type:	User Configured	
	1.2 Active:	Close Valid	
	1.3 Action:	Shutdown	
	1.4 Period:	From Always	
	1.5 Delay(0-20s):	2	
	Digital Input 6 Settings:		
	1.1 Type:	User Configured	
	1.2 Active:	Close Valid	
	1.3 Action:	ELE Trip	
	1.4 Period:	From Always	
	1.5 Delay(0-20s):	2	
	Digital Input 7 Settings:		
	1.1 Type:	User Configured	
	1.2 Active:	Close Valid	
	1.3 Action:	Warn	
	1.4 Period:	From Always	
	1.5 Delay(0-20s):	2	

Relay Output Setting		Relay Output 1 setting		
		1.1 Type	Common Alarm	
		1.2 Active	Active Open	
		Relay Output 2 setting		
		1.1 Type	Idle Control	
		1.2 Active	Active Open	
		Relay Output 3 setting		
		1.1 Type	Close Generator	
		1.2 Active	Active Open	
		Relay Output 4 setting		
		1.1 Type	Aux Input Active	
		1.2 Active	Active Open	
		Relay Output 5 setting		
		1.1 Type	Aux Input Active	
		1.2 Active	Active Open	
	Relay Output 6 setting			
	1.1 Type	Not Used		
	1.2 Active	Active Open		
ATS Switch Settings	1	Fail Warning Option:	Disable	
	2	Open Check Option:	Disable	
	3	Transfer Time(0-7200s):	2	Interval time from mains switch off to generator switch on; or from generator switch off to mains switch on.
	4	Check Time(0-20s):	2	
	5	Close Pulse Time(1-20s):	5	Pulse width of mains/generator switch on. When it is 0, means output constantly.
	6	Open Pulse Time(1-20s):	3	Pulse width of mains/generator switch off.
Mains Settings	1	Rated Volt(30-30000V):	230	
	2	Rated Freq(10-65Hz):	50	
	3	Main AC System:	0. 3P4W	0: 3P4W; 1: 3P3W; 2: 2P3W; 3: 1P2W.
	4	Normal Delay(0-3600s):	10	The delay from mains abnormal to normal.
	5	Abnormal Delay(0-3600s):	5	The delay from mains normal to abnormal.
	6	Loss Of Phase Option:	Enable	When the motor load needs to be enabled, and select 3 phase connection mode.
	7	Reverse Phase Option:	Enable	
	8	Volt Transform Settings		
		8.1 Option:	Disable	
		8.2 VT Primary (30-3000V):	100	
	8.3 VT Secondary (30-1000V):	100		
9	Main Volt Warning Settings			
	9.1 Over Volt Alarm Option:	Enable	Action when mains over volt Alarm.	

		9.2 Over Volt Trip(0-1500V):	276		
		9.3 Over Volt Return(0-1500V):	267		
		9.4 Over Volt Delay(0-3600s):	5		
		9.5 Under Volt Alarm Option:	Enable	Action when mains under volt Alarm.	
		9.6 Under Volt Trip(0-1500V):	184		
		9.7 Under Volt Return(0-1500V):	193		
		9.8 Under Volt Delay(0-3600s):	5		
	10	Main Freq Warning Settings			
			10.1 Over Freq Alarm Option:	Disable	Action when mains over frequency Alarm.
			10.2 Over Freq Trip(10-75Hz):	57	
			10.3 Over Freq Return(10-75Hz):	55	
			10.4 Over Freq Delay(0-3600s):	5	
			10.5 Under Freq Alarm Option:	Disable	Action when mains under frequency Alarm.
			10.6 Under Freq Trip(10-75Hz):	45	
			10.7 Under Freq Return(10-75Hz):	47	
		10.8 Under Freq Delay(0-3600s):	5		
Module Settings	1	Power On Mode:	Stop Mode		
	2	Slave Address:	1	Controller's address during remote sensing.	
	3	Language:	ENGLISH		
	4	Back Light(10-10000s):	15		
	5	Scroll Timer(0-1000s):	20		
	6	Module Date:			
	7	Module Clock:			
	8	Engineer Password:	0000		
	9	Technician Password:	0001		
	10	Operator Password:	0002		
Schedule Settings	1	Start On Option:	0		
	2	Start On Load:	Disable		
	3	Start On Cycle:	Not Onload		
	4	Schedule1-16 Setting		Monthly	
		4.1	Run Week Number:		
		4.2	Run Week Order:	1st Month	
		4.3	Run Clock:	Sunday	
	4.4	Run Time(0-30000m):	0:00		
Settings Maintenance	1	Maintenance 1-3 Setting		00000	
		1.1	Option:		
		1.2	Action:	Disable	
		1.3	Time Interval(1-5000h):	Warn	

		1.4 Limit Option:	30	
		1.5 Limit Time(1-24):	Disable	
GSM Settings	1	GSM Settings	1	
	2	Phone Number Setting	Disable	
		2.1 Phone NO1-5 Option:		
		2.2 Phone NO1 Value:	Disable	
	3	Notice Setting	0	
		3.1 Over Speed		
		3.2 Under Speed	Disable	
		3.3 Loss of Speed	Disable	
		3.4 Gen Over Freq	Disable	
		3.5 Gen Under Freq	Disable	
		3.6 Gen Over Volt	Disable	
		3.7 Gen Under Volt	Disable	
		3.8 Over Current	Disable	
		3.9 Fail To Stop	Disable	
		3.10 Charge Alt Fail	Disable	
		3.11 Bat High Volt	Disable	
		3.12 Bat Low Volt	Disable	
		3.13 Maintenance Over	Disable	
		3.14 Reverse Power	Disable	
		3.15 Over Power	Disable	
		3.16 ECU Warn	Disable	
		3.17 Gen Loss of Phase	Disable	
		3.18 Gen Reverse Phase	Disable	
		3.19 Switch Fail Warn	Disable	
		3.20 Temp Sensor Open	Disable	
		3.21 Temp High Warn	Disable	
		3.22 Temp Low Warn	Disable	
		3.23 Oil Sensor Open	Disable	
		3.24 Oil High Warn	Disable	
		3.25 Oil Low Warn	Disable	
		3.26 Fuel Sensor Open	Disable	
		3.27 Fuel High Warn	Disable	
		3.28 Fuel Low Warn	Disable	
		3.29 Sensor1 Open	Disable	
3.30 Sensor1 High Warn	Disable			
3.31 Sensor1 Low Warn	Disable			
3.32 Sensor2 Open	Disable			
3.33 Sensor2 High Warn	Disable			
3.34 Sensor2 Low Warn	Disable			
3.35 GSM Com Fail	Disable			
3.36 Input1 Warn	Disable			
3.37 Main Normal	Disable			
3.38 Main Fail	Disable			
3.39 Gen Start	Disable			
3.40 Gen Stop	Disable			

		3.41 Main On Load	Disable		
		3.42 Gen On Load	Disable		
		3.43 System Not In Auto Mode	Disable		
		3.45 System In Auto Mode	Disable		
	4	Back Content Setting			
			4.1 Works Mode	Disable	
			4.2 Main Volt(V)	Disable	
			4.3 Gen Volt(V)	Disable	
			4.4 Load Current(A)	Disable	
			4.5 Main Freq(HZ)	Disable	
			4.6 Gen Freq(HZ)	Disable	
			4.7 Load KW(KW)	Disable	
			4.8 Load KVA(KVA)	Disable	
			4.9 Load PF	Disable	
			4.10 Bat Volt(V)	Disable	
			4.11 Charge Volt(D+)(V)	Disable	
			4.12 Water Temp(C)	Disable	
			4.13 Oil Press(KPa)	Disable	
			4.14 Fuel Level(%)	Disable	
	4.15 Speed(RPM)	Disable			
	4.16 Total Hour(s)	Disable			
	4.17 Engine State	Disable			
	4.18 Alarm State	Disable	Gens Message		
Gens Message	1	Module:		Genset Module:	
	2	Hardware Version:		Genset Hardware Version:	
	3	Software Version:		Genset Software Version:	
	4	ID:		Genset ID:	

11.3. Defined contents of configurable input ports

No.	Type	Description
1	Users Configured	<p>Including following functions:</p> <p>-----</p> <p>Warning: warn only, not shutdown. Shutdown: alarm and shutdown immediately. Trip and stop: alarm, generator unloads and shutdown after hi-speed cooling. Trip: alarm, generator unloads but not shutdown. Indication: indicate only, not warning or shutdown.</p> <p>-----</p> <p>From safety on: detecting after safety on run delay. From crank: detecting as soon as start. Always: input is active all the time. Never: input inactive</p>
2	Alarm Mute	Can prohibit“Audible Alarm”output when input is active.
3	Reset Alarm	Can reset shutdown alarm and trip alarm when input is active.

4	Aux High Temp	Connected sensor digital input.
5	Aux Low OP	Connected sensor digital input.
6	Inhibit Alarm Stop	Prohibit any alarm and shutdown action.
7	Remote Start On Load	In Auto mode,when input active,genset can be started and with load after genset is OK;when input inactive, genset will stop automatically.
8	Remote Start Not On Load	In Auto mode, when input is active, genset can be started and without load after genset is OK; when input is inactive, genset will stop automatically.
9	Aux Manual Start	In Auto mode,when input active, genset will start automatically;when input inactive,genset will stop automatically.
10	Simulation Mains OK	In Auto mode,mains are normal when input is active.
11	Simulation Mains Fail	In Auto mode, mains are abnormal when input is active.
12	Panel Lock	Generator related operations are banned, switch query interface can be used.
13	Inhibit Auto Stop	In Auto mode, during generator normal running, when input is active, inhibit generator shutdown automatically.
14	Inhibit Auto Start	In Auto mode, inhibit generator start automatically when input is active.
15	Inhibit Scheduled	In Auto mode,inhibit scheduled run genset when input is active.
16	Inhibit Phone Message Start	Prohibiting boot via SMS.
17	Inhibit Gens Load	Prohibit genset switch on when input is active.
18	Inhibit Mains Load	Prohibit mains switch on when input is active.
19	Auto Mode Lock	When the input is active, the controller will operate in automatic mode, you can not select the test mode and manual mode.
20	Auto Mode Invalid	When input is active,controller won't work under Auto mode. AUTO key and simulate auto key input does not work.
21	Idle Control Mode	Under voltage/frequency/speed protection is inactive.
22	Instrument Mode	All outputs are prohibited in this mode.
23	Aux Gens Closed	Connect generator loading switch's Aux. Point.
24	Aux Mains Closed	Connect mains loading switch's Aux. Point.
25	Aux Raise Speed	This configuration is for the use of motor adjust the speed of the unit, and raise speeding output with control motor.When this switch is closed, raise speed output will turn off.
26	Aux Drop Speed	This configuration is for the use of motor adjust the speed of the unit, and drop speeding output with control motor.When this switch is closed, raise speed output will turn off.
27	Reset Maintenance	Controller will set maintenance time and date as default when input is active.
28	Simulate Stop key	An external button can be connected and pressed as simulate panel.
29	Simulate Manual key	
30	Simulate Manual Test key	
31	Simulate Auto key	
32	Simulate Start key	
33	Simulate G-Load key	
34	Simulate M-Load key	
35	Lamp Test	All LED indicators are illuminating when input is active.
36	60Hz Active	Use for CANBUS engine and it is 60Hz when input is active.
37-39	Alternative Config1-3	Users can set different parameters to make it easy to select current configuration via input port.

11.4. Enable definition of programmable output ports

No.	Type	Description
0	Not Used	
1	Fuel Relay	Action before the starter motor, open the fuel system in advance. Usually controls the governor's power and fuel solenoid valve.
2	Crank Relay	When starting the motor action, often connected to the starter relay.
3	Air Flap	Action in over speed alarm stop and emergence stop. It also can close the air inflow the engine.
4	Audible Alarm	Action in warning, shutdown, trips. Can be connected outside alarm. When programmable input port is active of "alarm mute", can prohibit its output.
5	Louver Control	Action in genset starting and disconnect when genset stopped completely.
6	Fuel Pump Control	It is controlled by fuel pump of level sensor's limited threshold.
7	Heater Control	It is controlled by heating of temperature sensor's setting bound.
8	Cooler Control	It is controlled by cooler of temperature sensor's setting bound.
9	Pre-oil Supply Output	Action from "crank on" to "safety on".
10	Excite Generator	Output in start period. If there is no gens frequency during hi-speed running, output 2 seconds again.
11	Pre-Lubricate	Actions in period of pre-heating to safety run.
12	Remote PC Output	This port is controlled by communication (PC).
13	Idle Control	Used for engine which has idles. Pull in before starting and pull out after into hi-speed warming; Pull in during stopping idle mode and pull out after shutdown completed.
14	Raise Speed	Action in hi-speed warming run.
15	Drop Speed	Action in period of stop idle mode to time of wait for stopping completely.
16	Reserved	
17	Reserved	
18	ETS Control	Used for engines with ETS electromagnet. Pull in when stop idle is over and pull out when set "ETS delay" is over.
19	Close Generator	Generator load conditions are ripe for action, control power closing switch with load. It is a continuous output.
20	Open Generator Pulse	The same role, but is not a continuous output, but only the output pulses of a preset time. This time set in the timer configuration.
21	Open Generator	Generator stop action, control power generation closing switch uninstal.
22	Open Generator Pulse	The same role, but is not a continuous output, but only the output pulses of a preset time. This time set in the timer configuration.
23	Open Breaker	Gens whether or mains is opened, will be output. It is a common sub-gate output.
24	Close Mains	Control switch of mains is load.
25	Close Mains Pulse	
26	Open Mains	
27	Open Mains Pulse	
28	Reserved	
29	Generator OK	Action when gens are normal.
30	Generator Available	Action in period of gens ok to hi-speed cooling.

31	ECU Stop	Used for ECU engine and control its stop.
32	ECU Power	Used for ECU engine and control its power.
33	Crank Success	Pull in when detects a successful start signal.
34	GSM Power	Power for GSM module (GSM module is power-off reset when GSM communication failed).
35	Mains OK	Action when mains normal.
36	In Stop Mode	
37	In Manual Mode	
38	In Manual Test Mode	
39	In Auto Mode	
40	Generator On Load	
41	Mains On Load	
42	Reserved	
43	Common Alarm	Action in gens common warning, common shutdown, common trips alarm.
44	Common trip shutdown	The generators any kind of trip and downtime will produce such an alarm action.
45	Common Shutdown	Generator any downtime will have such alarm action.
46	Common Trip Alarm	Generators will produce any kind of trip the alarm action.
47	Common Warn Alarm	Generators of any kind of public warning alarm is generated action.
48	Battery Hight Voltage	An action in battery's over voltage warning alarm.
49	Battery Low Voltage	Action in battery's low voltage warning alarm.
50	Charging failure	Action in charge alt fail warning alarm.
51	ECU Warn	Indicate ECU sends a warning alarm signal.
52	ECU Shutdown	Indicate ECU sends a shutdown alarm signal.
53	ECU Communication Fail	Indicate controller not communicates with ECU.
54	Emergency Stop	Action in emergency stop alarm.
55	Failed To Start	Action in failed start alarm.
56	Failed To Stop	Action in failed stop alarm.
57	Under Speed Warn	Action in under speed warning.
58	Under Speed Shutdown	Action in under speed shutdown.
59	Over Speed Warn	Action in over speed warning.
60	Over Speed Shutdown	Action in over speed shutdown alarm.
61	Gens Over Freq Warn	Action in gens over frequency warning.
62	Gens Over Freq Shutdown	Action in gens over frequency shutdown alarm.
63		Action in gens over voltage warning.
64	Gens Over Volt Warn	Action in gens over voltage shutdown.
65	Gens Over Volt Shutdown	Action in gens low frequency warning.
66	Gens Under Freq Warn	Action in gens low frequency shutdown.
67	Gens Under Voltage Warn	Action in gens low voltage warning.
68	Gens Under Volt Shutdown	Action in gens low voltage shutdown.
69	Gens Loss Of Phase	Action in gens loss phase.
70	Gens Reverse Phase	Action in gens reverse phase.
71	Over Power	When the load power exceeds a preset value action is to prevent excessive damage to the engine power.
72	Reverse Power	Action in controller detects gens have reverse power.

73	Over Current	Action in over current.
74	Mains Inactive	Action in mains Inactive .
75	Mains Over Freq	Action in mains over frequency.
76	Mains Over Voltage	Action in mains over Voltage.
77	Mains Under Freq	Action in mains under frequency.
78	Mains Under Volt	Action in mains under Voltage.
79	Mains Reverse Phase	When phase sequence of 3 phase input mistake.
80	Mains Loss Of Phase	Action in mains loss Of Phase.
81	High Temp Warn	Action in high temperature warning alarm.
82	Low Temp Warn	Action in low temperature warning alarm.
83	High Temp Shutdown	Action in high temperature Shutdown alarm.
84	Low Oil Pressure Warn	Action in low oil pressure warning alarm.
85	Low Oil Pressure Shutdown	Action in low oil pressure shutdown.
86	OP Sensor Open	Action when oil pressure sensor are open circuit.
87	Low Level Warn	Action when controller has low oil level alarm.
88	Config1 High Warn	
89	Config1 Low Warn	
90	Config1 High Shutdown	
91	Config1 Low Shutdown	
92	Config2 High Warn	
93	Config2 Low Warn	
94	Config2 High Shutdown	
95	Config2 Low Shutdown	
96-102	Aux Input 1-7 Active	
103	Reserved	
104-109	Custom Period 1-6	
110-115	Custom Combined 1-6	

11.5. Defined period output

Defined Period output is made of 2 parts, period output S1 and condition output S2 .

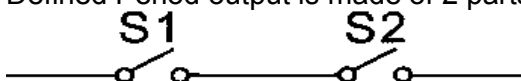

While S1 and S2 are TRUE synchronously, OUTPUT;

While S1 or S2 is FALSE, NOT OUTPUT;

Period output S1, can set generator's one or more period output freely, can set the delayed time and output time after into period.

Condition output S2; can set as any conditions in output ports .

▲NOTE: when delay time and output time both are 0 in period output S1, it is TRUE in this period .

Example:

Output period: start

Delay output time: 5s

Output time: 3s

Condition output contents: output port 1 is active (Valid / Invalid : close when active/disconnect when inactive)

Output port 1 active, after enter “starts time” and delay 5s, this defined period output is outputting, after 3s, stop outputting;

As shown below



11.6. Custom combined output

Defined combination output is composed by 3 parts, condition output S1 or S2 and condition output S3.

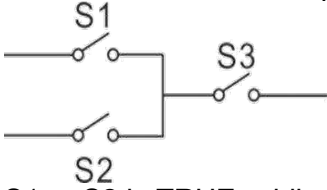

S1 or S2 is TRUE, while S3 is TRUE, Defined combination output is outputting;
S1 and S2 are FALSE, or S3 is FALSE, Defined combination output is not outputting.

▲ NOTE: S1, S2, S3 can be set as any contents except for “defined combination output” in the output setting..

▲ NOTE: 3 parts of defined combination output (S1, S2, S3) couldn't include or recursively include themselves.

Example:

Contents of probably condition output S1: output port 1 is active;

Close when probably condition output S1 is active /inactive: close when active (disconnect when inactive);

Contents of probably condition output S2, output port 2 is active;

Close when probably condition output S2 is active /inactive: close when active (disconnect when inactive);

The closed output S3 valid / invalid and conditions: when active (disconnect when inactive)

When input port 1 active or input port 2 active, if input port 3 is active, Defined combination output is outputting; If input port 3 inactive, Defined combination output is not outputting;

When input port 1 inactive and input port 2 inactive, whatever input port 3 is active or not, Defined combination output is not outputting.

As shown below

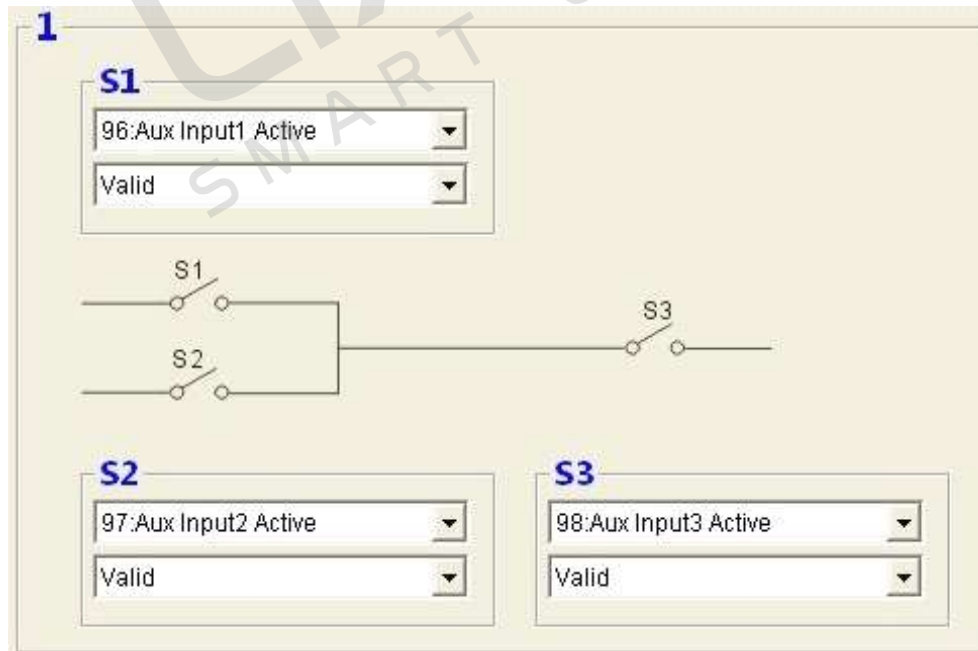

11.7. Sensor selection list

Temperature Sensor	Oil Pressure Sensor	Level Sensor
0 Not used	0 Not used	0 Not used
1 VDO 120°C	1 VDO0-10BAR	1 VDO 0-180ohm
2 CURTIS	2 CURTIS	2 SGD
3 VOLVO-EC	3 VOLVO-EC	3 SGH
4 DATCON	4 DATCON 10BAR	4 Custom Res Curve
5 SGX	5 SGX	5 Custom 4-20mA curve
6 SGD	6 SGD	6 Reserved
7 SGH	7 SGH	7 Reserved
8 PT100	8 Custom Res Curve	8 Reserved
9 Custom Res Curve	9 Custom 4-20mA curve	9 Reserved
10 Custom 4-20mA curve	10 Reserved	10 Reserved
11 Reserved	11 Reserved	11 Reserved
12 Reserved	12 Reserved	12 Reserved

11.8. Pressure unit conversion table

Unit	N/m ² Pa	kg/cm ²	bar	1b/in ² .psi
1Pa	1	1.02 ×10 ⁻⁵	1 ×10 ⁻⁵	1.45 ×10 ⁻⁴
1kgf/cm ²	9.8 ×10 ⁴	1	0.98	14.2
1Bar	1 ×10 ⁵	1.02	1	14.5
1Psi	6.89 ×10 ³	7.03 ×10 ⁻²	6.89 ×10 ⁻²	1

NOTE:

1. Is there a difference if standard curve of sensor with the use of sensors, can be change by itself in the custom curve, when the sensor selection is "no", the curve of sensor doesn't work.
2. If the corresponding sensors, only alarm switch, is the sensor must be set to "no", otherwise likely stop alarm or warning.

11.9. Conditions of crank disconnect selection

Crank Disconnect Conditions

Number of start attempts (1-10times)

<input checked="" type="checkbox"/>	Gens Freq	<input type="text" value="12.0"/>	Hz	<input type="range" value="24.0"/>	24.0%	(0-200%)
<input checked="" type="checkbox"/>	Speed	<input type="text" value="360"/>	RPM	<input type="range" value="24.0"/>	24.0%	(0-200%)
<input checked="" type="checkbox"/>	Oil Pressure	<input type="text" value="200"/>	KPa	<input type="range" value="200Kpa"/>	200Kpa	(0-1000KPa)
<input checked="" type="checkbox"/>	D+	<input type="text" value="3.0"/>	V	<input type="range" value="3.0V"/>	3.0V	(3.0-32.0V)

As shown above, check the desired options, multiple choice or do not choose.

1. There are 4 conditions to make starter disconnected with engine, that is, speed sensor, generator frequency, Charge D+ and engine oil pressure. They all can be used separately. We recommend that engine oil pressure should be used with speed sensor and generator frequency together, in order to make the starter motor separated with engine immediately and can check crank disconnect exactly.
2. Speed sensor is the magnetic equipment which is installed in the starter for detecting flywheel teeth.
3. When set as speed sensor, must ensure that the number of flywheel teeth is the same as the setting, otherwise, "over speed stop" or "under speed stop" may be caused.
4. If genset without speed sensor, please don't select corresponding items, otherwise, "start fail" or "loss speed signal" may be caused.
5. If genset without oil pressure sensor, please don't select corresponding items.
6. If not select generator in crank disconnect setting, controller will not collect and display the relative power quantity (can be used in water pump set); if not select speed sensor in crank disconnect setting, the rotating speed displayed in controller is calculated by generator frequency and number of poles.
7. If the generator without magneto-electric sensor and Oil pressure sensor, the "Charger D+" is optional as a starter motor separation condition. It is recommended to select "Oil Pressure + Charger D+" for safety.

12. Typical application

1. Three kinds of remote controllers recommended **Dongguan Feirui Electronics Co.,Ltd** ,wireless data transmission equipment DTU680G ,The product has a wireless data transmission, GPS location data, as long as there is cell phone signal can be transmitted through the mobile phone network, innovation and independent R & D,dedicated communication module, an infinite distance, data security and reliability features.
2. If the engine starter battery voltage is 24V, measuring starter output port, output port and stop the fuel outlet (based on user configuration dependent) on the battery negative resistance should not be less than 2 ohms, if less than 2 ohms in the corresponding current output port another extension greater than 30A relay. If the engine starter battery voltage of 12V, output measurement start, fuel output port and output port shutdown on battery negative resistance should not be less than 1 ohm, if less than 1 ohm in the corresponding output current is greater than another extension 30A relay.

Three-phase three-wire connection wiring diagram(to LXC7X20 example)

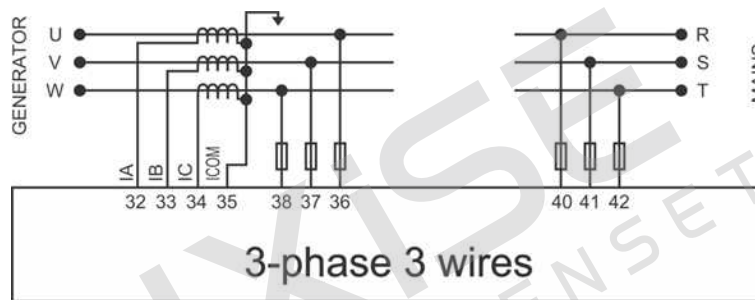

Single-phase two-wire connection wiring diagram(to LXC7X20 example)

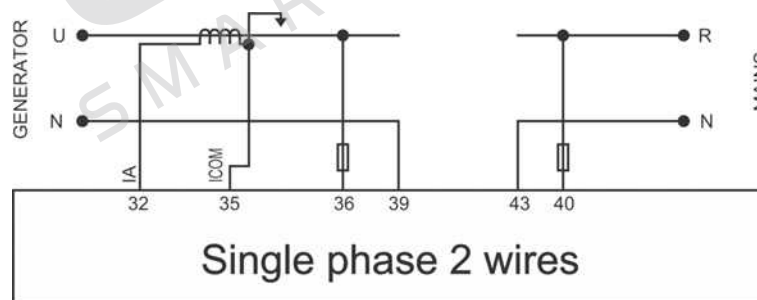

Two-phase three-wire connection wiring diagram(to LXC7X20 example)

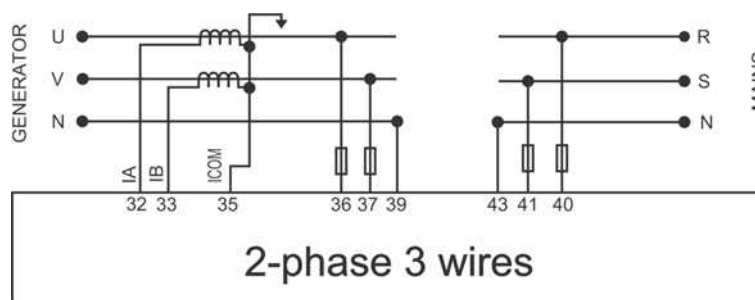

LXC7X10 Typical application diagram

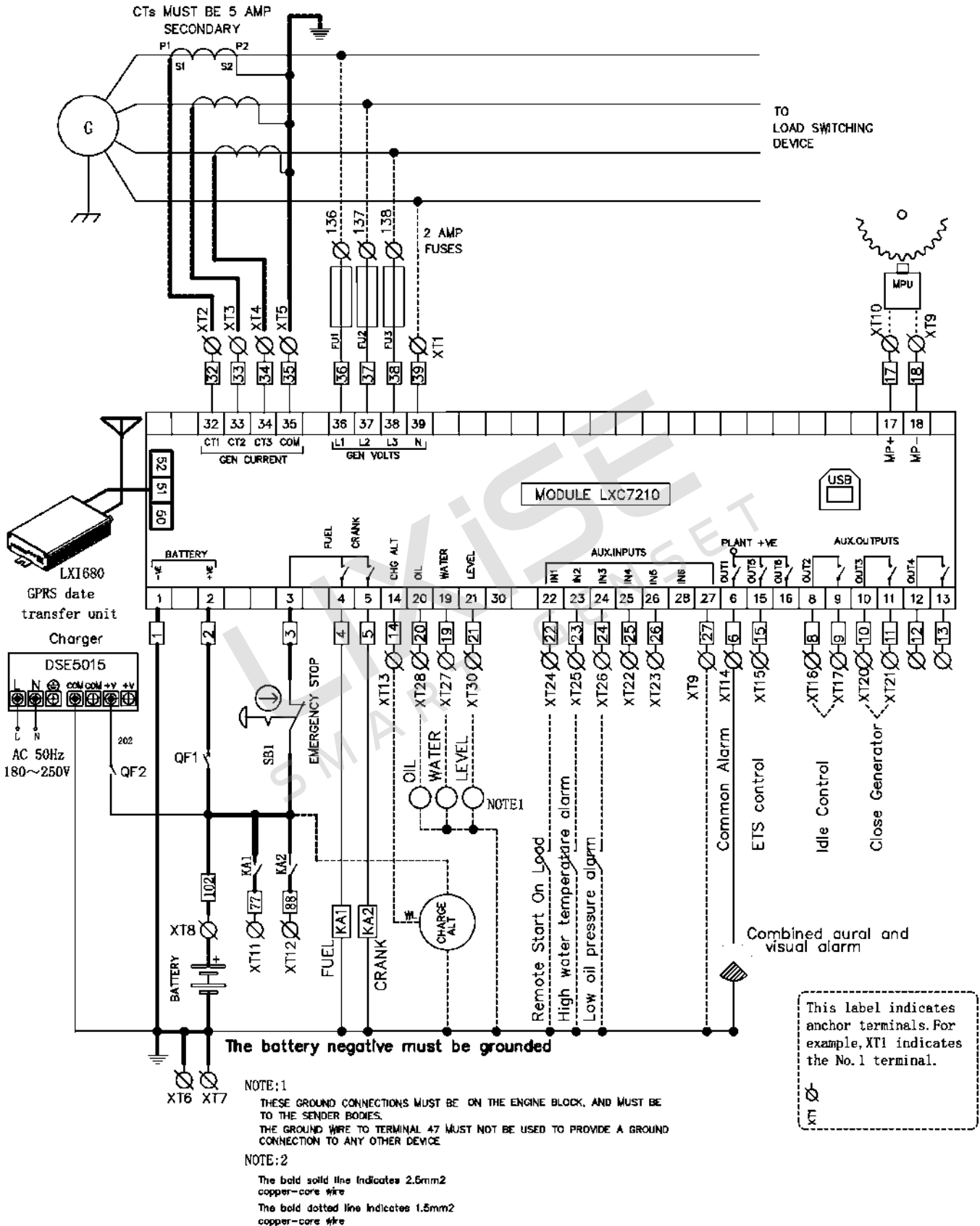

LXC7X20 Typical application diagram

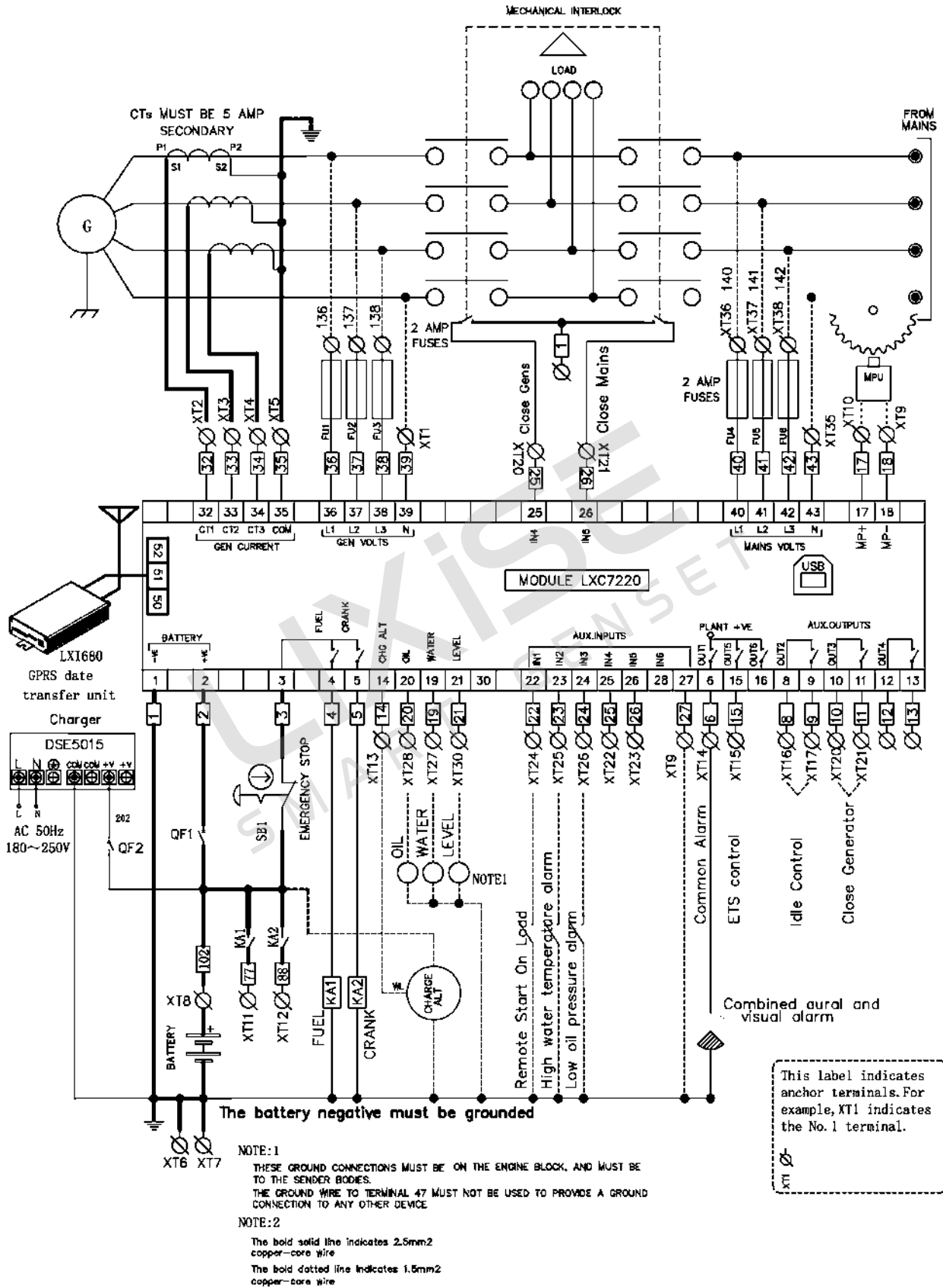

13. Installation

LXC7XXX Controller is panel built-in design; it is fixed by clips when installed. The controller's overall dimensions and cutout dimensions for panel, please refer to as following.

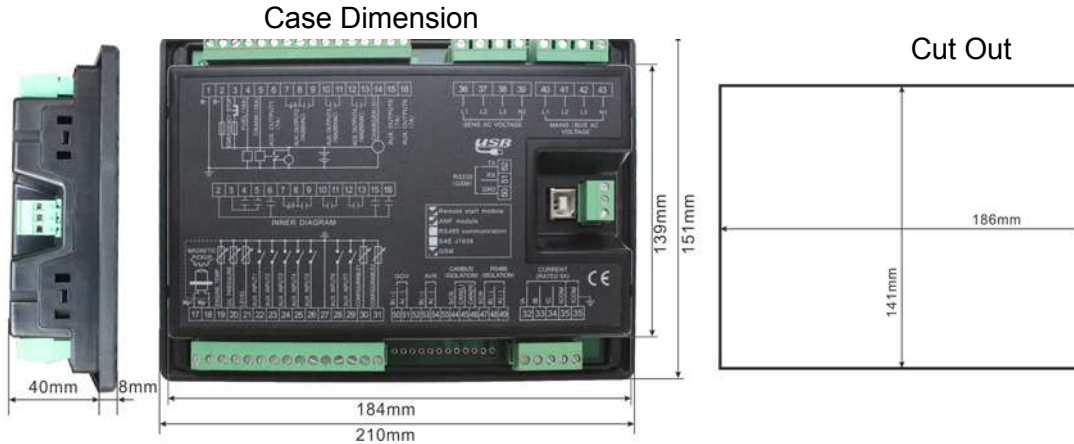

This section contains a number of very important considerations.

Controller installation instructions notes			
NO.	Item	Note,Warning, Caution	Description
1	Voltage Input	▲:8~35VDC	Negative of battery must be connected with the shell of starter stable.
2	Connect controller to battery	▲:Wire ≥2.5mm ²	The diameter of wire which from power supply to battery must be over 2.5mm ² .
3	Battery Charger	▲:Charger must be connected directly to the battery.	Please firstly connect output wires of charger to battery's positive and negative directly, then, connect wires from battery's positive and negative to controller's positive and negative input ports in order to prevent charge disturbing the controller's normal working.
4	Speed Sensor Input	▲:2 cores shielding line	Speed sensor is the magnetic equipment which be installed in starter and for detecting flywheel teeth. Its connection wires to controller should apply for 2 cores shielding line. The shielding layer should connect with No.18 terminal in controller while another side is hanging in air. The else two signal wires are connected with No.17 and No.18 terminals in controller. The output voltage of speed sensor should be within (1~24) VAC (effective value) during the full speed.
5	Output And Expand Relays	▲:Please add freewheel diode to both ends of expand relay's coils or, increase resistance-capacitance return circuit	All outputs of controller are relay contact output type. If need to expand the relays, please add freewheel diode to both ends of expand relay's coils (when coils of relay has DC current) or, increase resistance-capacitance return circuit (when coils of relay has AC current), in order to prevent disturbance to controller or others equipment.
6	AC Input	▲:ICOM port must be connected to negative pole of battery controller power. ⚠:When there is load current, transformer's secondary side prohibit from open circuit.	Current input of controller must be connected to outside current transformer. And the current transformer's secondary side current must be 5A. At the same time, the phases of current transformer and input voltage must correct. Otherwise, the current of collecting and active power maybe not correct.
7	Withstand Voltage Test	▲:When controller had been installed in control panel, if need the high voltage test, please disconnect controller's all terminal connections, in order to prevent high voltage into controller and damage it.	

14. Common faults and exclusion

Following in my controller process more common failure and troubleshooting, if there is a failure of the other can not be solved, please contact my company.

Faults	Possible Solutions
Controller no response with power	Check starting batteries; Check controller connection wirings; Check DC fuse.
Genset shutdown	Check the bottom of the main interface warning; Check the genset AC voltage; Check DC fuse.
Controller emergency stop	Check emergence stop button is correct or not; Check whether the starting battery positive be connected with the emergency stop input; Check whether the circuit is open.
Low oil pressure alarm after crank disconnect	Check the oil pressure sensor and its connections.
High water temp alarm after crank disconnect	Check the temperature sensor and its connections.
Shutdown Alarm in running	Check related switch and its connections according to the information on LCD; Check programmable inputs.
Crank not disconnect	Check fuel oil circuit and its connections; Check starting batteries; Check speed sensor and its connections; Refer to engine manual.
Starter no response	Check starter connections; Check starting batteries.
Genset running while ATS not transfer	Check ATS; Check the connections between ATS and controllers.
RS485 communication is abnormal	Check connections; Check setting of COM port is correct or not; Check RS485's connections of A and B is reverse connect or not; Check whether damage RS485transfer model; Check whether damage communication port of PC.

15. Product packaging

This product should be following sets:

- (1) 1 piece of controller model **LXC7XX0**.
- (2) 4 pieces of fixed cards.
- (3) 1 piece of product certificate.
- (4) 1 piece of product manual.

LXC7X20/LXC7X10 Generator remote monitoring program

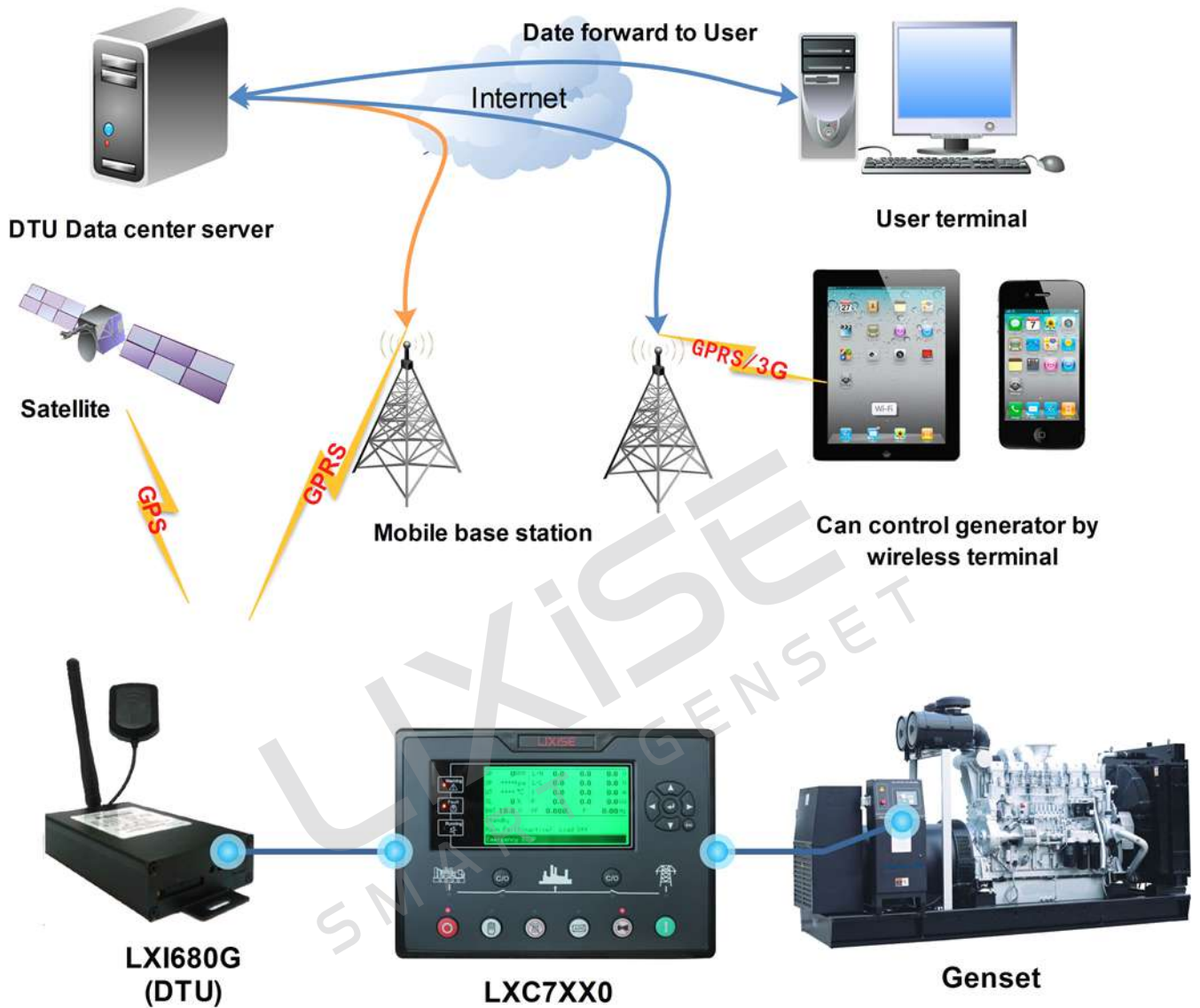

**Dongguan Tuancheng Automation
Equipment Co.,LTD.**

Tel:+86-769-23836636

Fax:+86-769-23166296

http://www.lixise.com

http://www.lixise.net

E-mail:sales@lixise.com

Add: Wentang Road, Chashang
industrial zone #18, Dongcheng,
Dongguan, Guangdong, China